

Motivation

- Cycling is good for your **health** and good for the **environment**.
- However, most countries **cycle significantly less than they could** (i.e., The Netherlands has 25x as many cycle trips than the US)
- This means there's a significant margin for **growing** the global cyclist population impacting **sustainability** and **population health**.

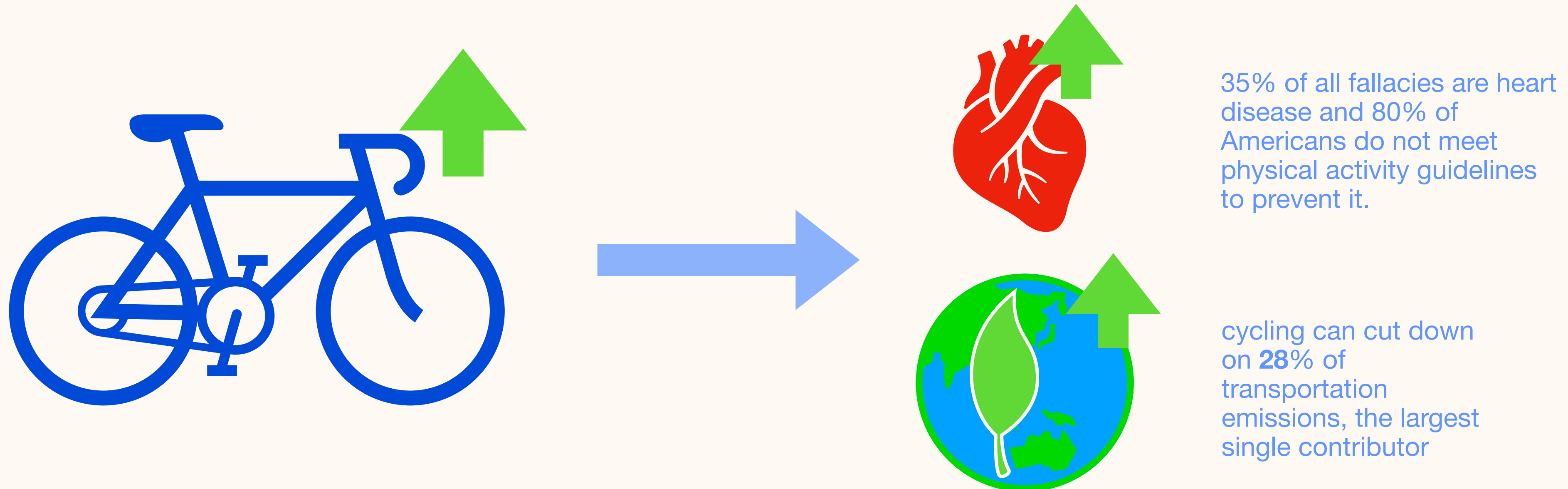

Formative Study

Why Aren't People Cycling?

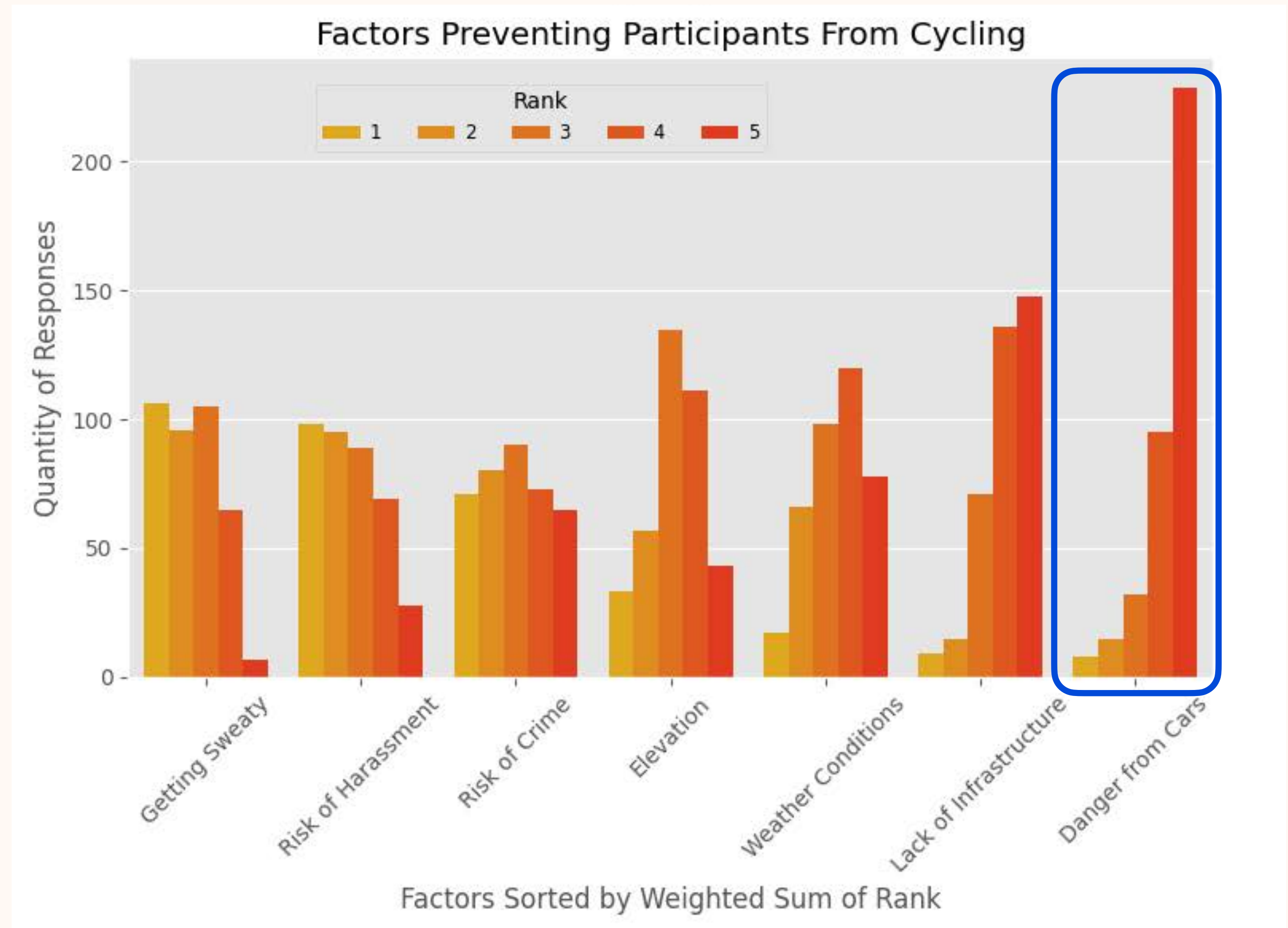
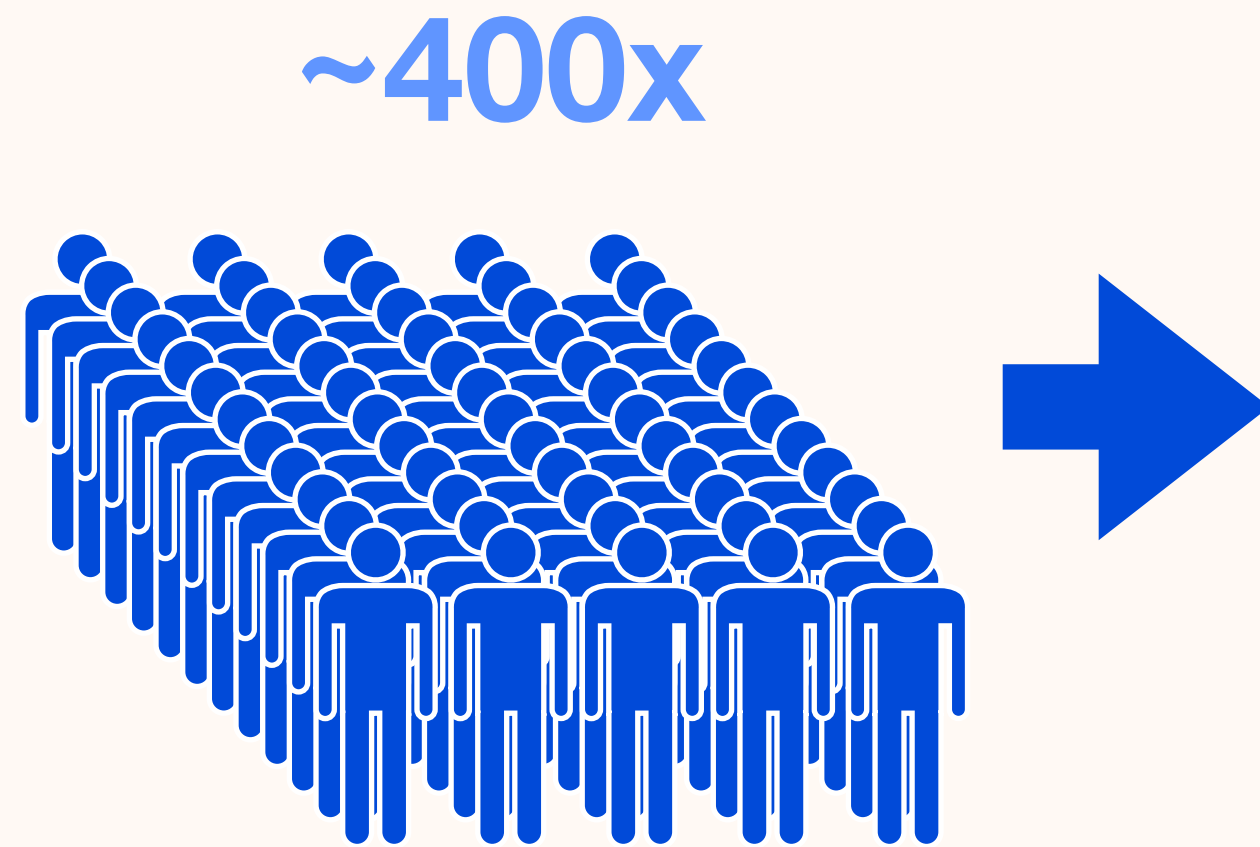

Formative Study

The barrier to entry is safety

Better Infrastructure

“It's only dangerous when the infrastructure doesn't adequately separate cyclists from car traffic.”

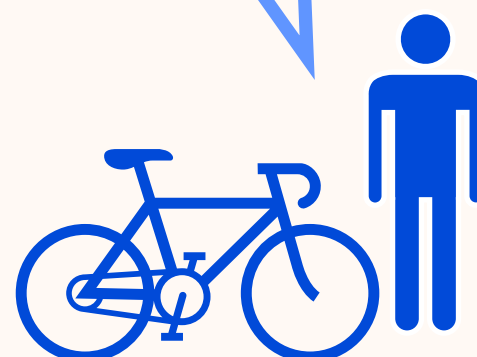

Driver Behavior

“It's not the cycling that's dangerous - it's the distracted or aggressive drivers.”

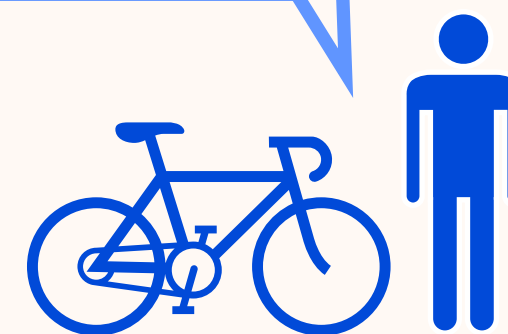

Knowing Wear to Go

“Safety is very segment dependent. Without a full citywide cycling network that will always remain the case.”

“**Knowledge of streets and traffic patterns is essential**, but once you have a familiar and well considered route, it is very safe”

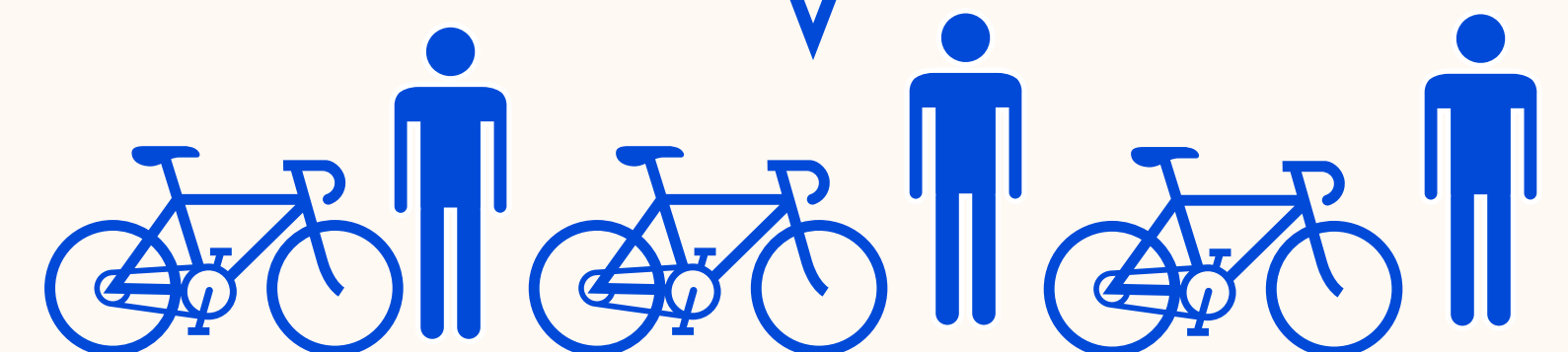

Formative Study

Summary of Findings

- **Fear of being hit by a car** is the primary factor preventing cycling adoption.
- There is varying safety across the road network.
- Experienced cyclists use **mental maps** to mitigate risk by riding safer routes.
- Measuring and sharing these maps with novice cyclists can lower the barrier of entry to cycling.
- Share the benefits of cycling without risk.

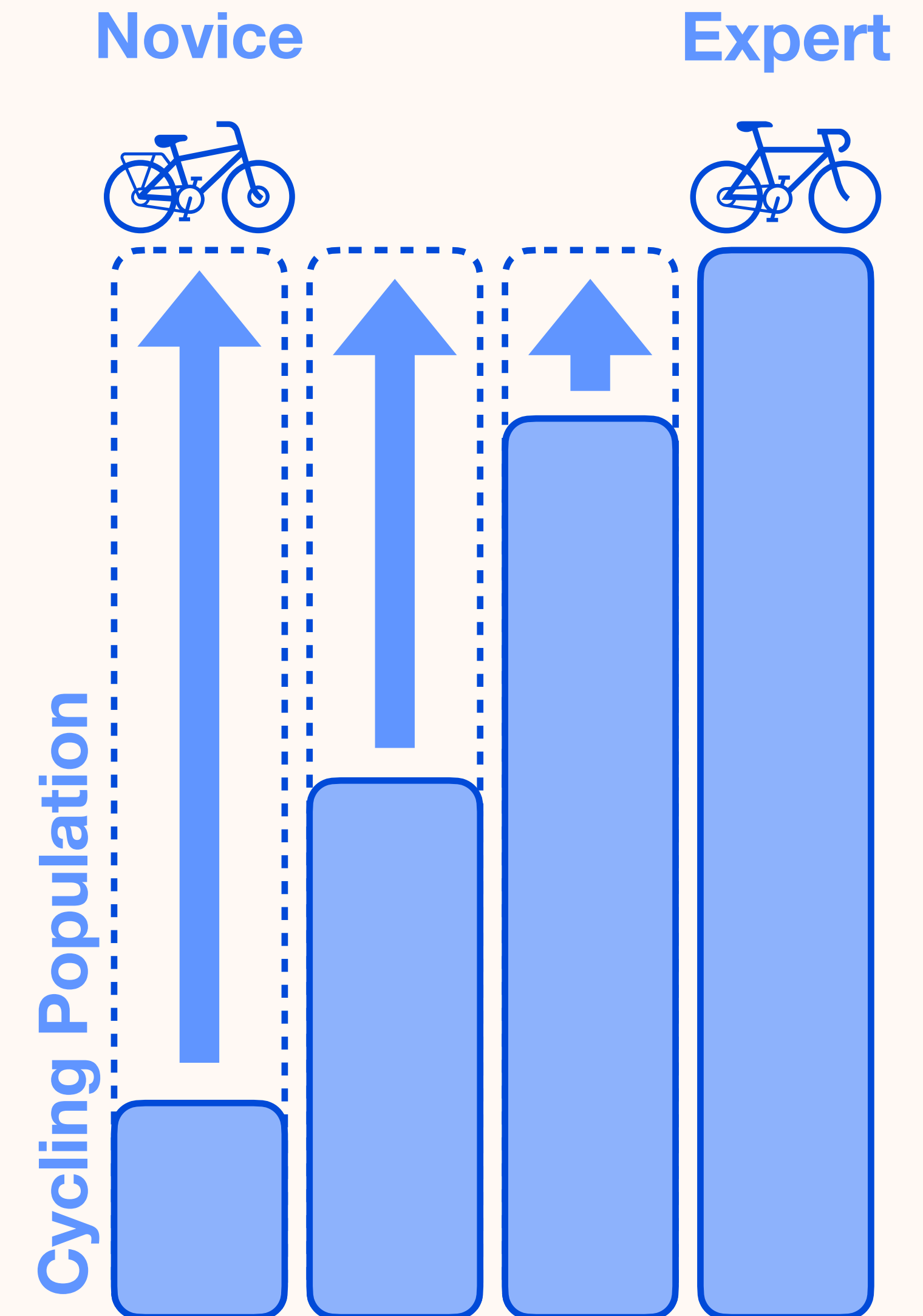

Motivation

Formative Study Findings

**So how do we measure safety
across the road network?**



Measuring Safety

Identifying a signal of safety

- **Empirically through Historic Collisions**
 - **Infrequent** (reduced statistical utility).
 - **Lagging indicator** (people have to get hurt as part of data collection).

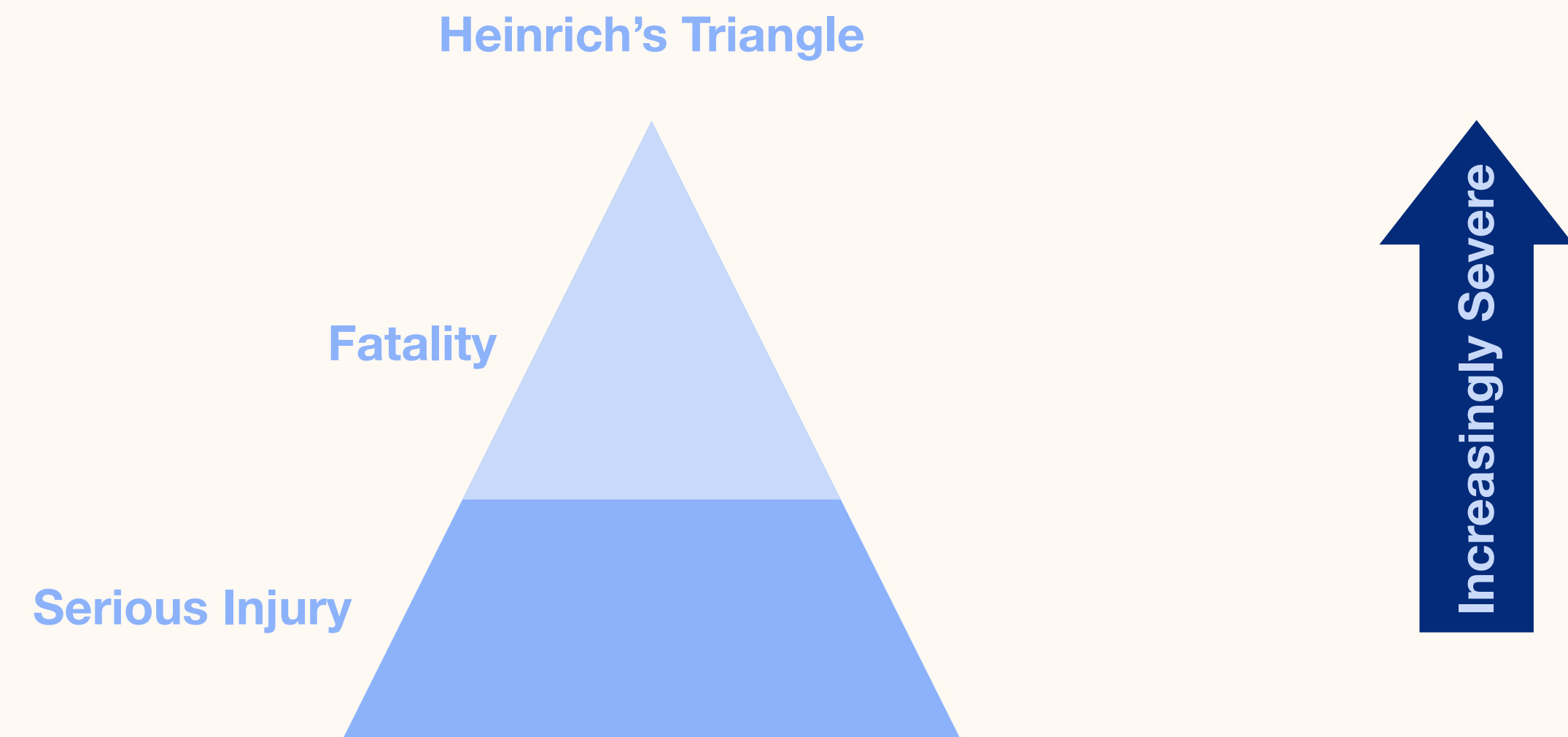

Measuring Safety

Identifying a signal of safety

- **Near-misses:** when vehicles nearly but do not collide.
 - **Highly correlated** with collisions.
 - **More frequent** than collisions.
 - **Leading indicator** that do not require anyone to be hurt.
 - **Directly measures safety** through real events.

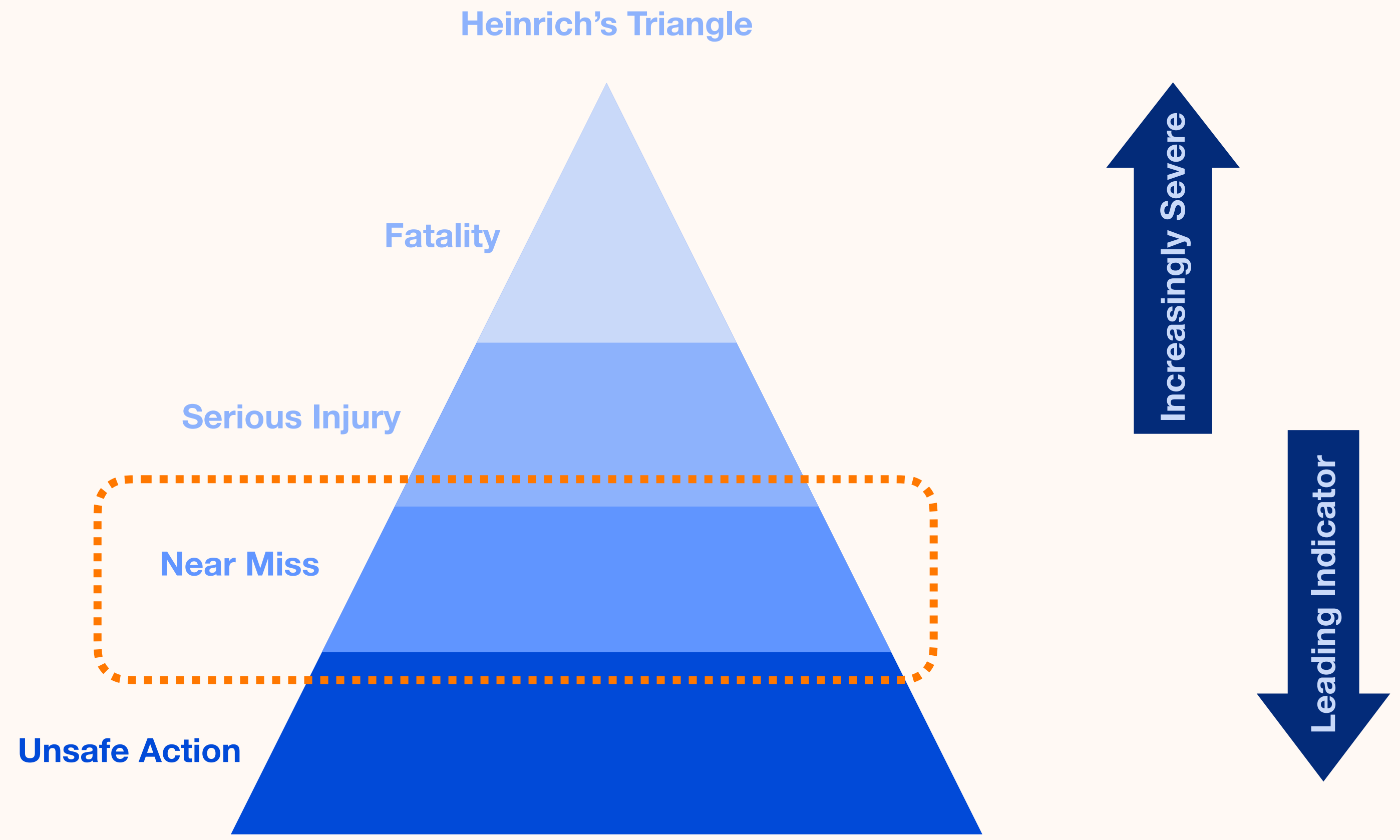

Measuring Safety

Identifying a signal of safety

- A common near-miss for cyclists is...

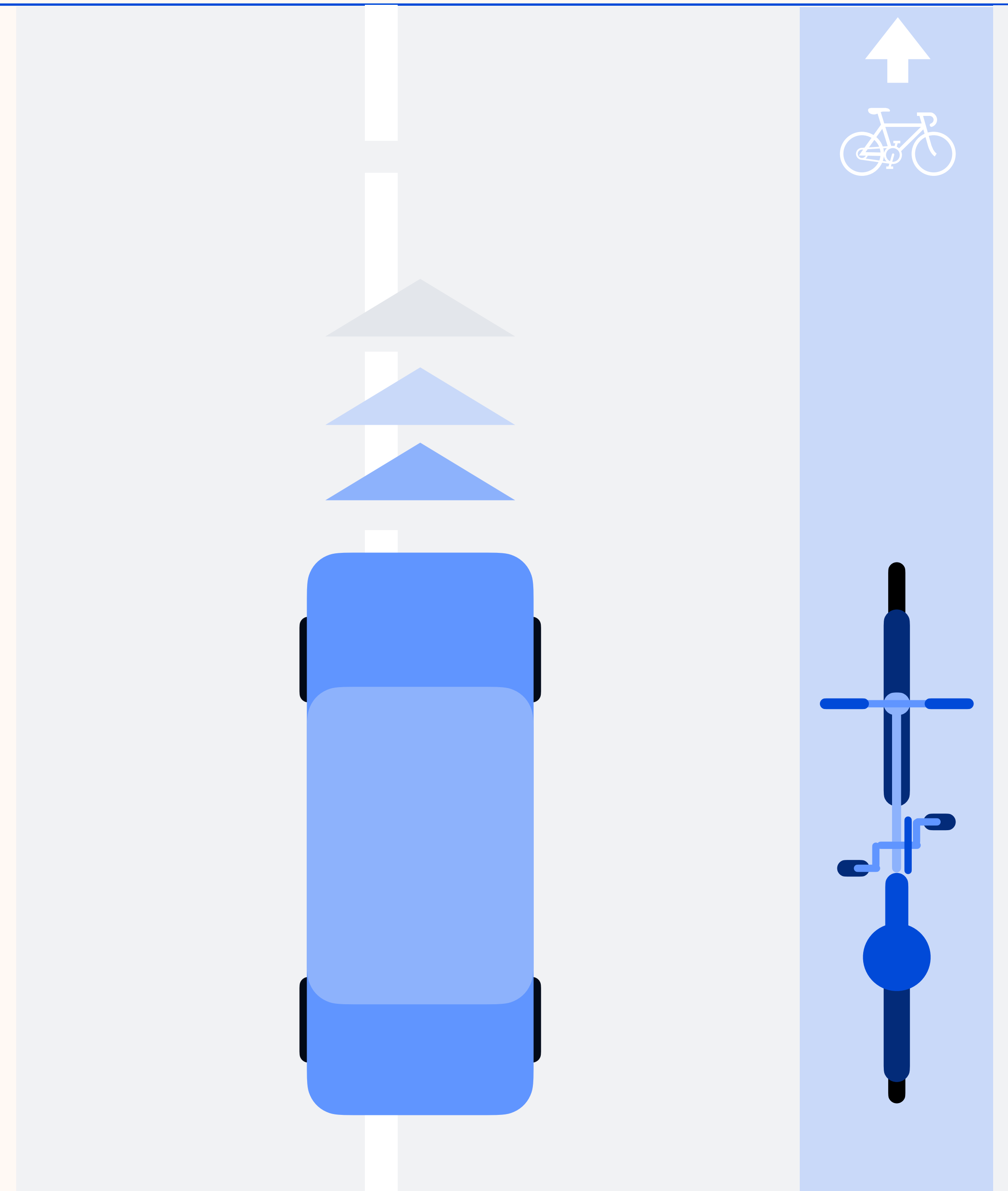

Measuring Safety

Identifying a signal of safety

- A common near-miss for cyclists is a close-pass.

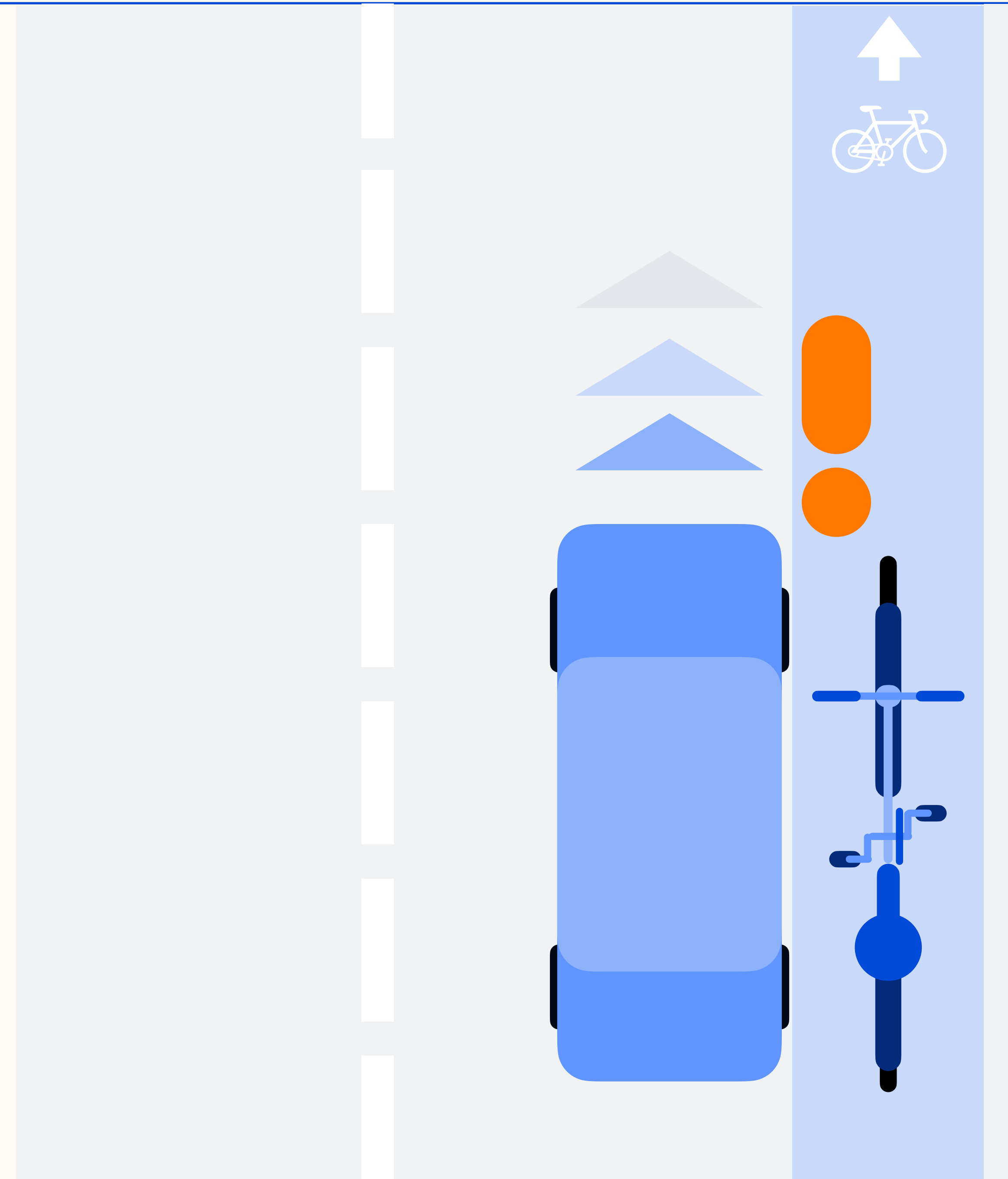

Measuring Safety

Identifying a signal of safety

- A common near-miss for cyclists is a close-pass.
- Sideswipe collisions are the most commonly observed form of collision.
- Underreported in collision datasets despite widespread experience.

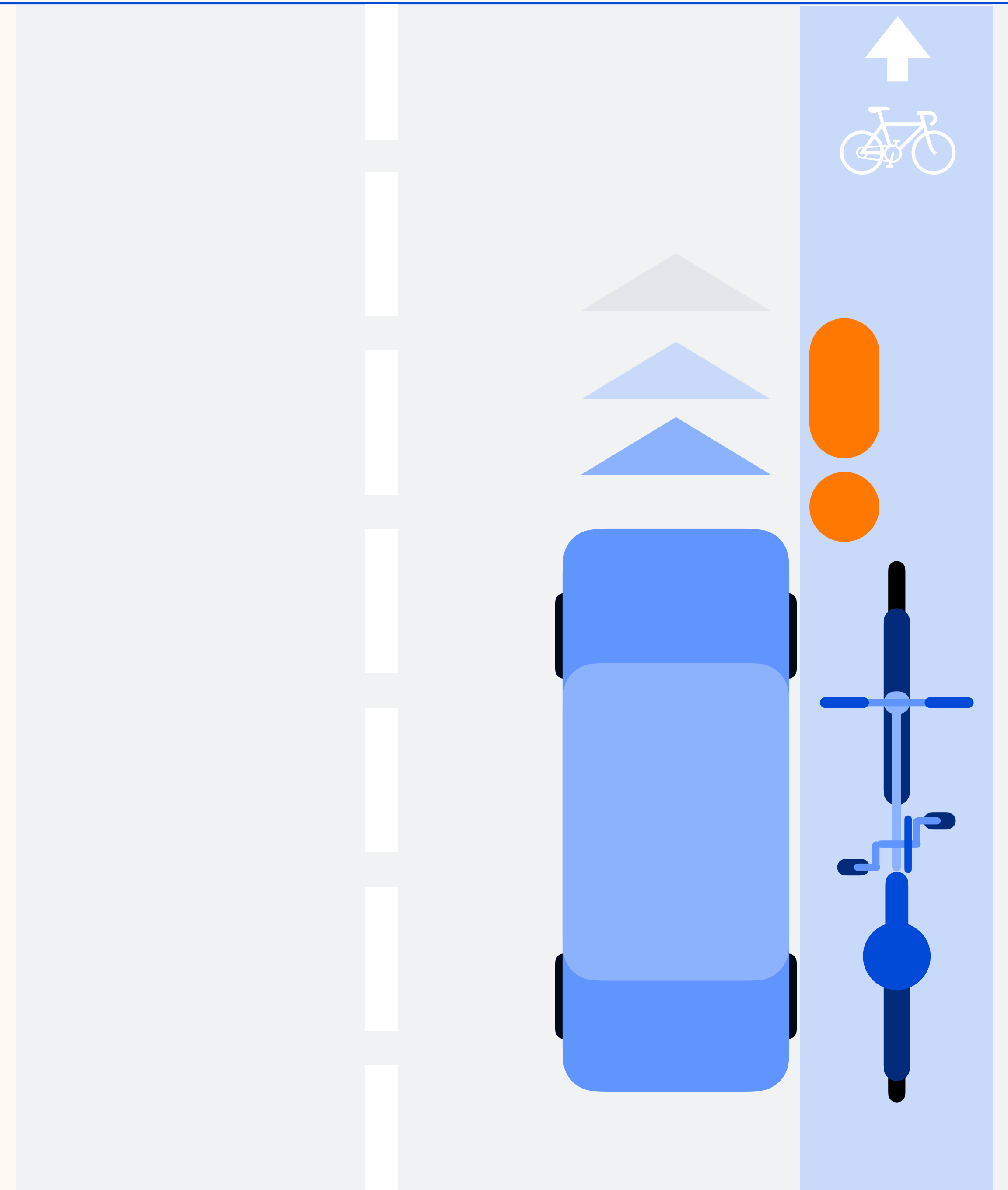

Measuring Safety

Identifying a signal of safety

- A common near-miss for cyclists is a close-pass.
- Sideswipe collisions are the most commonly observed form of collision.
- Underreported in collision datasets despite widespread experience.

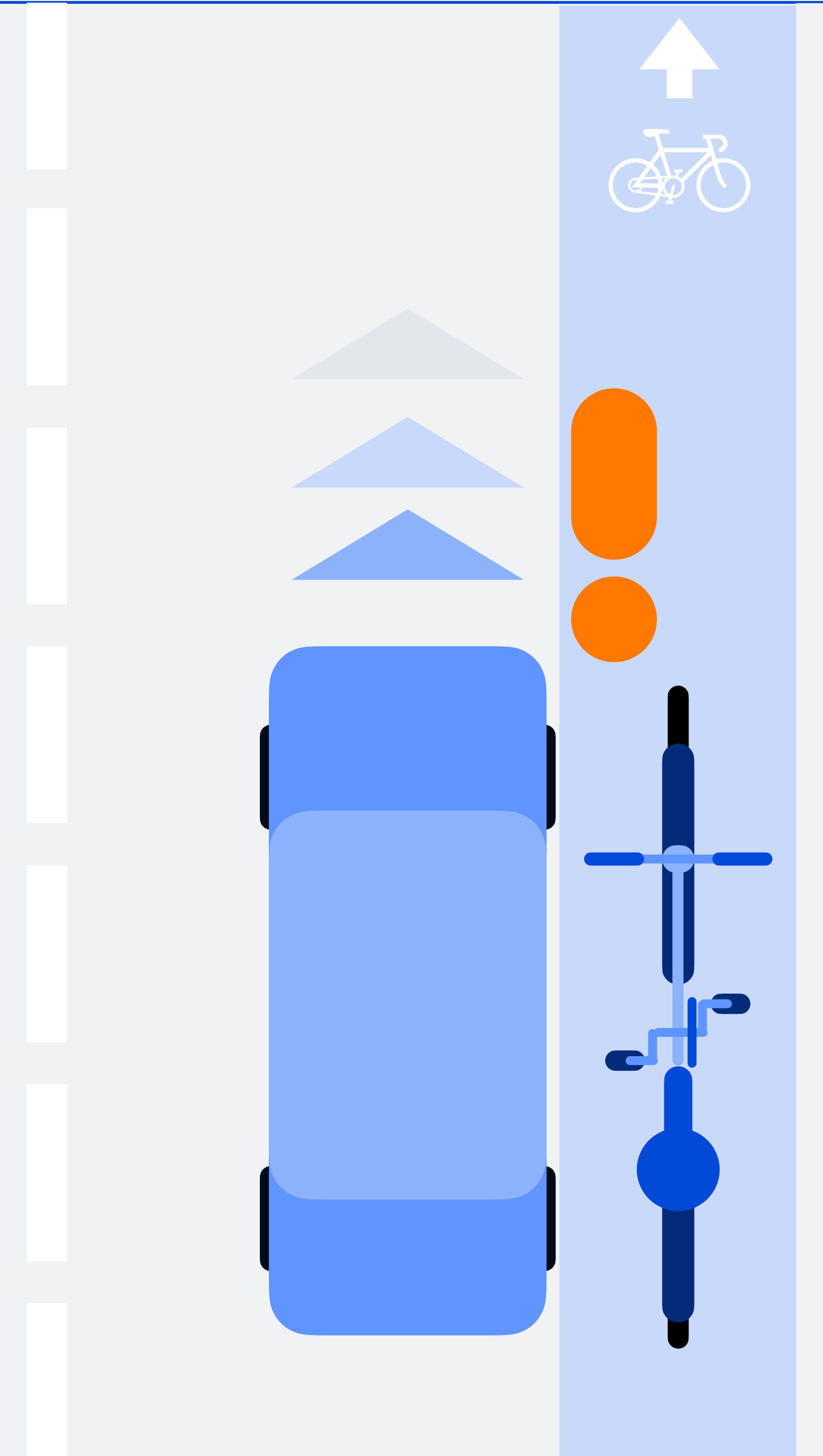

**So lets do it
automatically!**

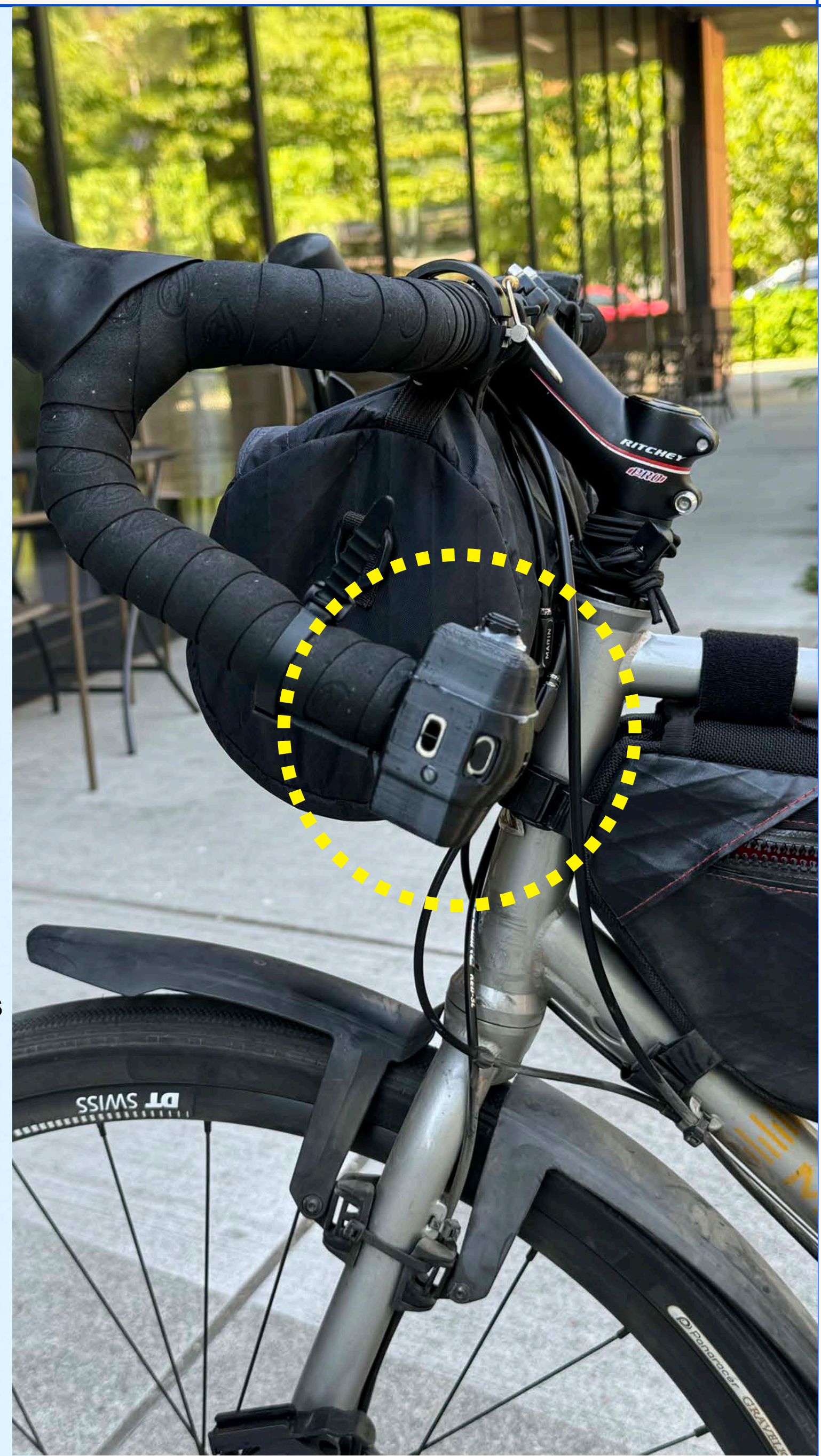
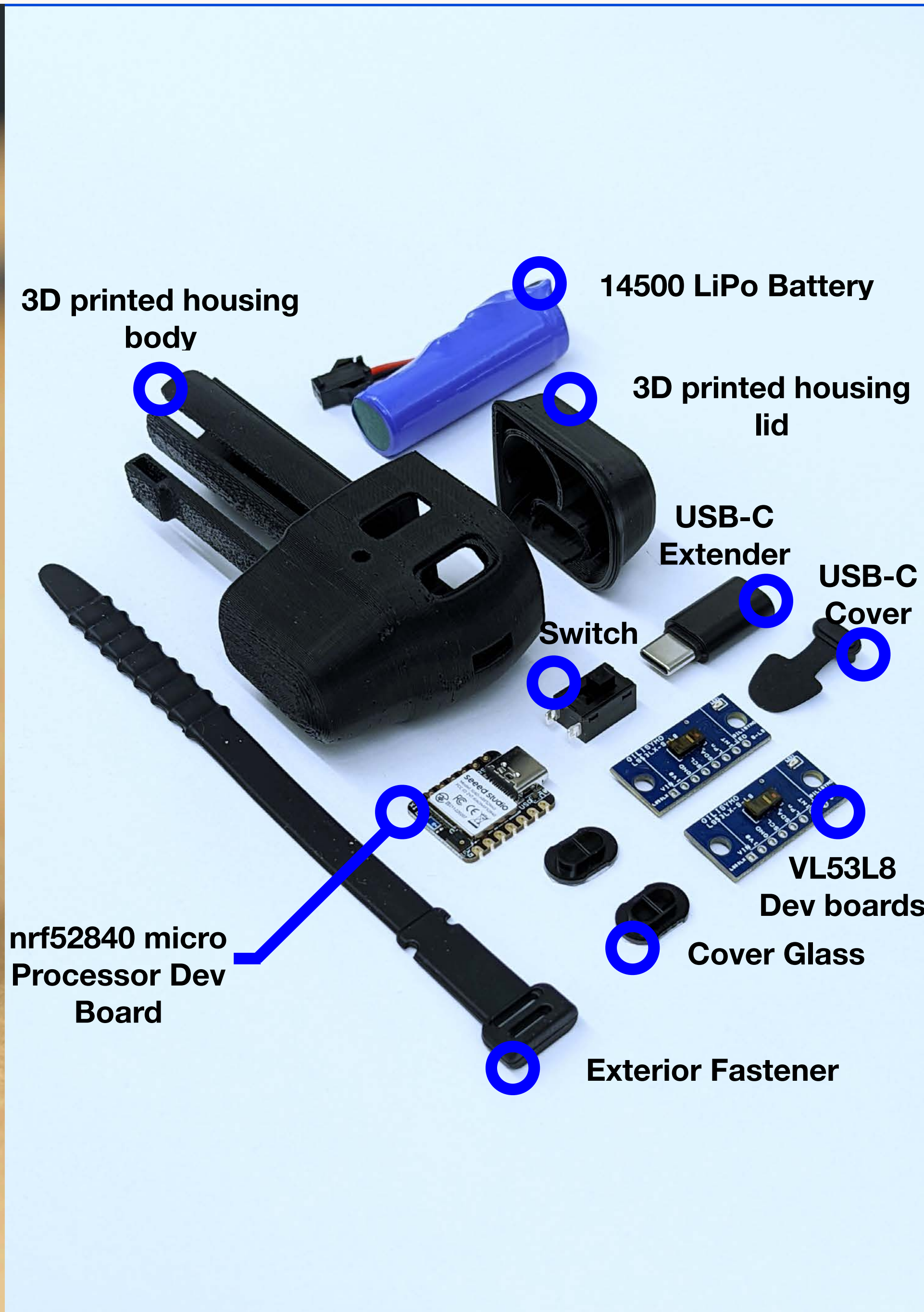



3D

passively senses close-passes as cyclists ride and aggregates a city-wide map across cyclists.

nrf5 Pro

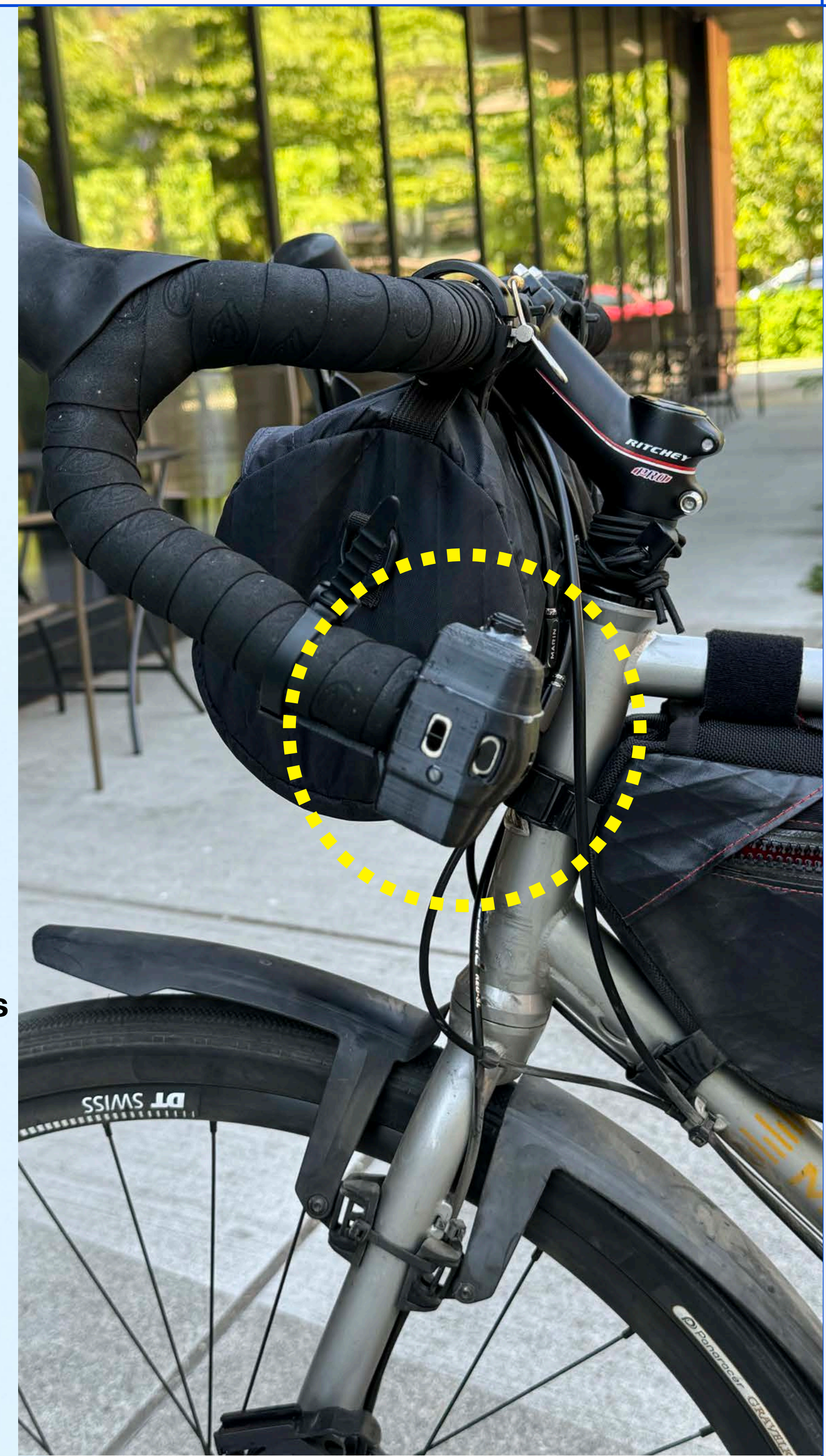

ng

3-C
ver

.8
ards

How it Works

Two Proximity Sensors

- For the full theory of operation, see paper
- Two proximity sensors captures relative velocity of pass.
- 4x4 proximity grid allows distinguishing between large and small objects.

Nothing Detected

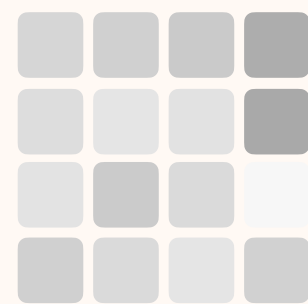

Partial

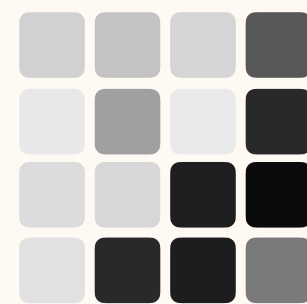

Close Proximity

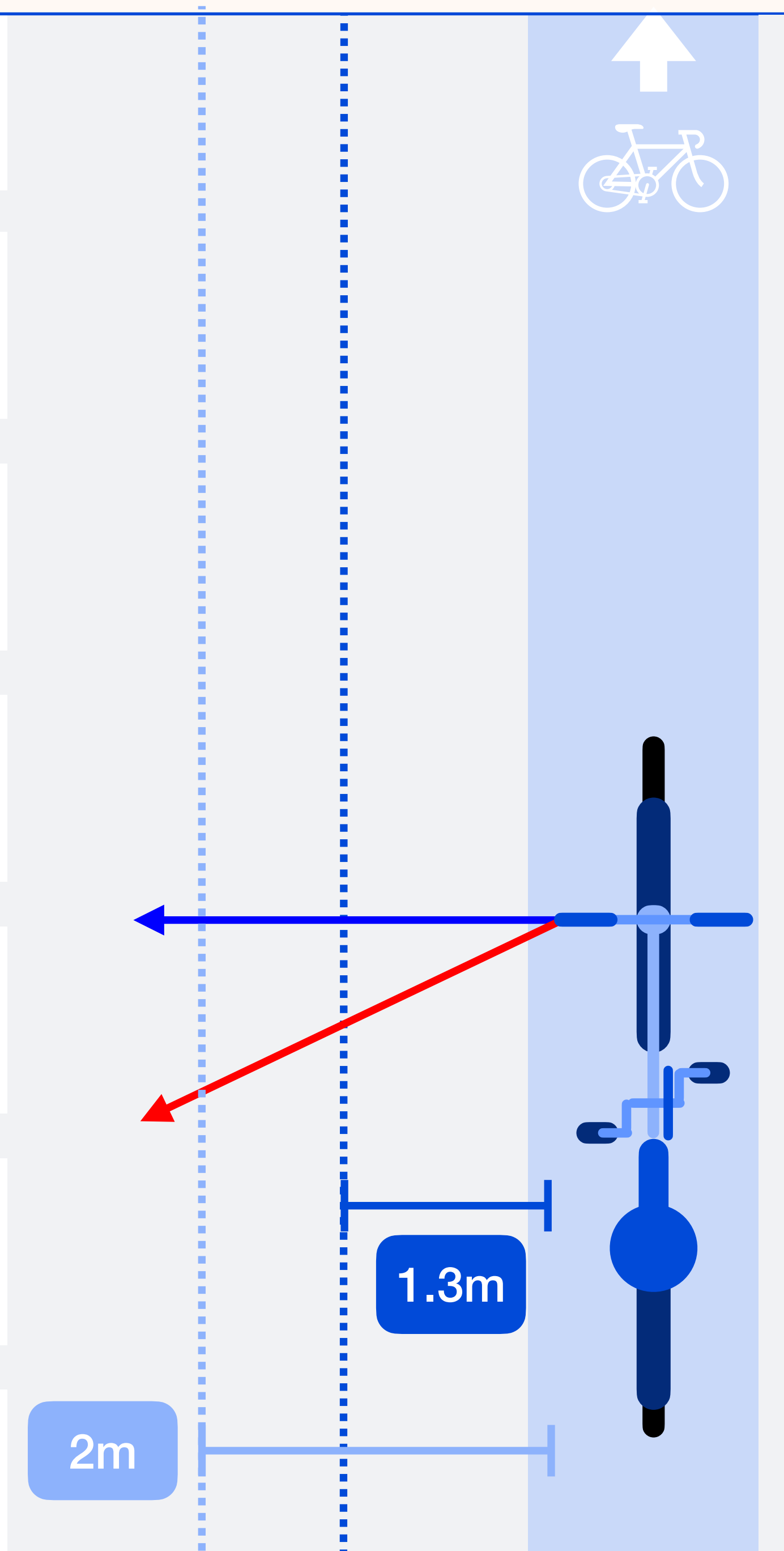
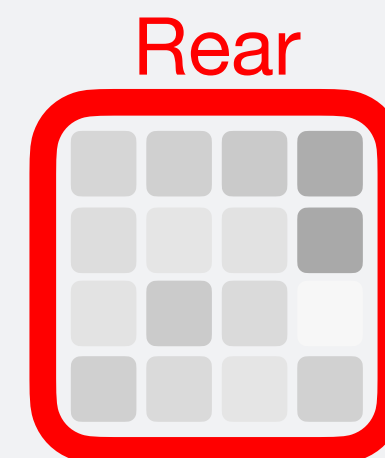
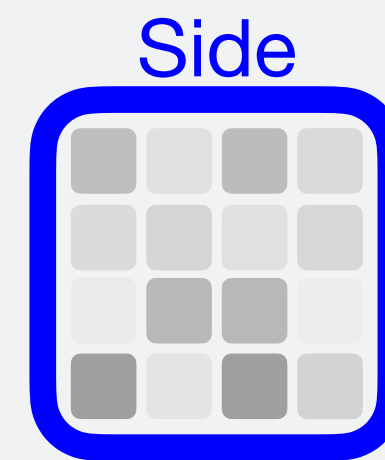
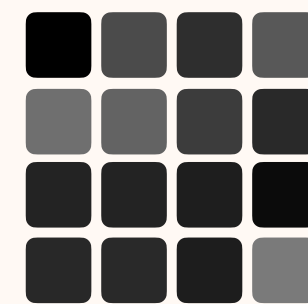

How it Works

Example of car passing bike

Nothing Detected

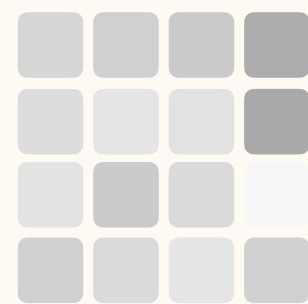

Partial

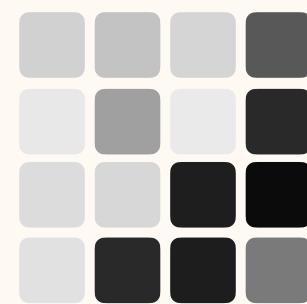

Close Proximity

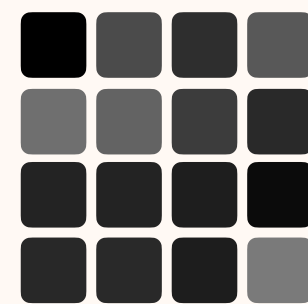

Side

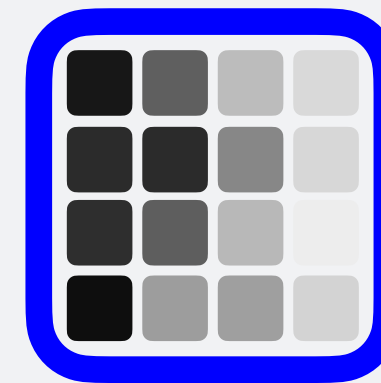

Rear

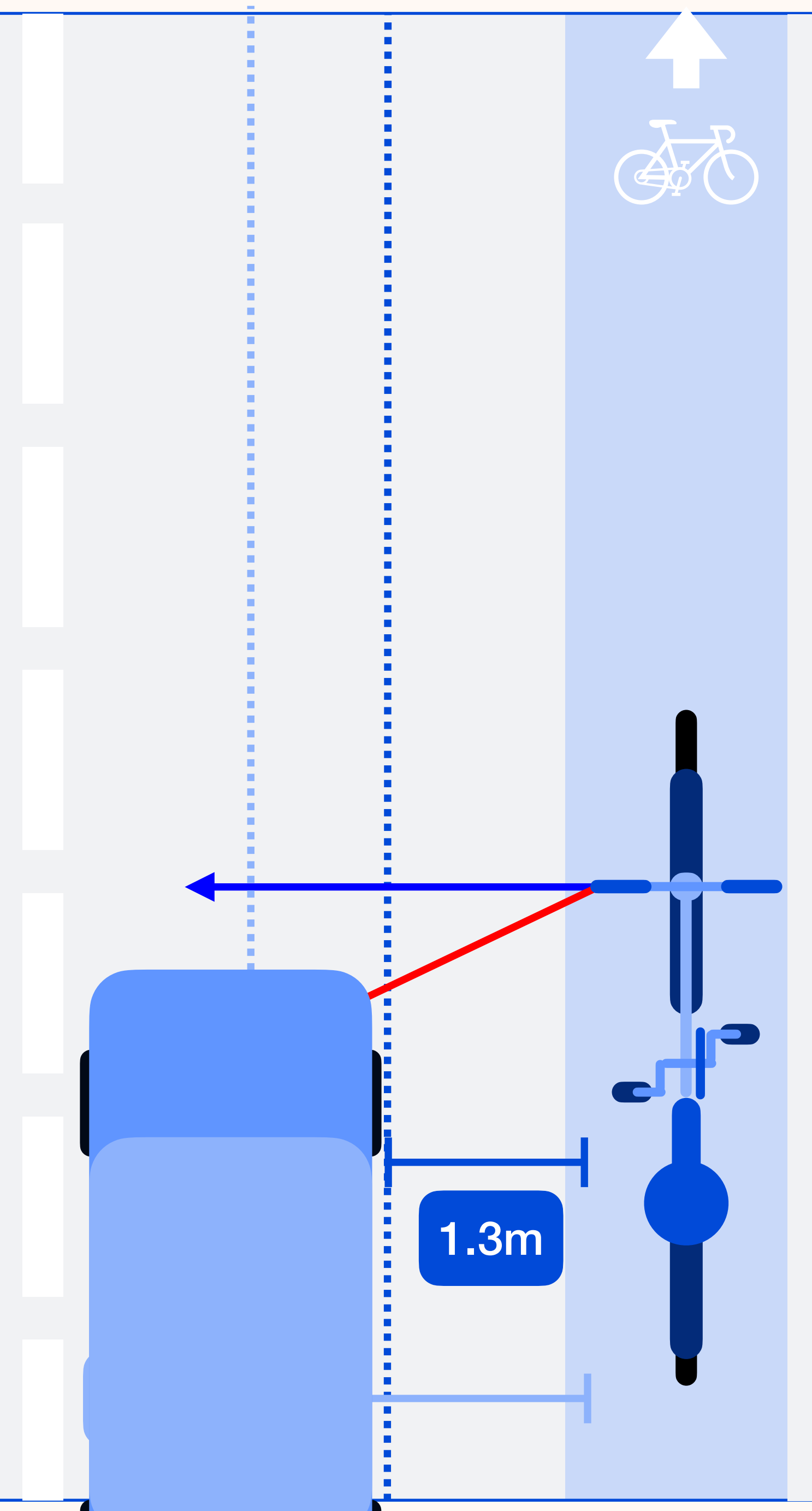

How it Works

Example of car passing bike

Nothing Detected

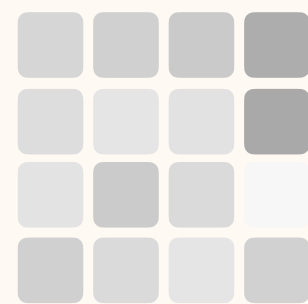

Partial

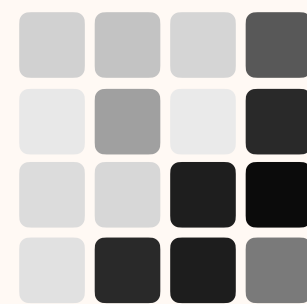

Close Proximity

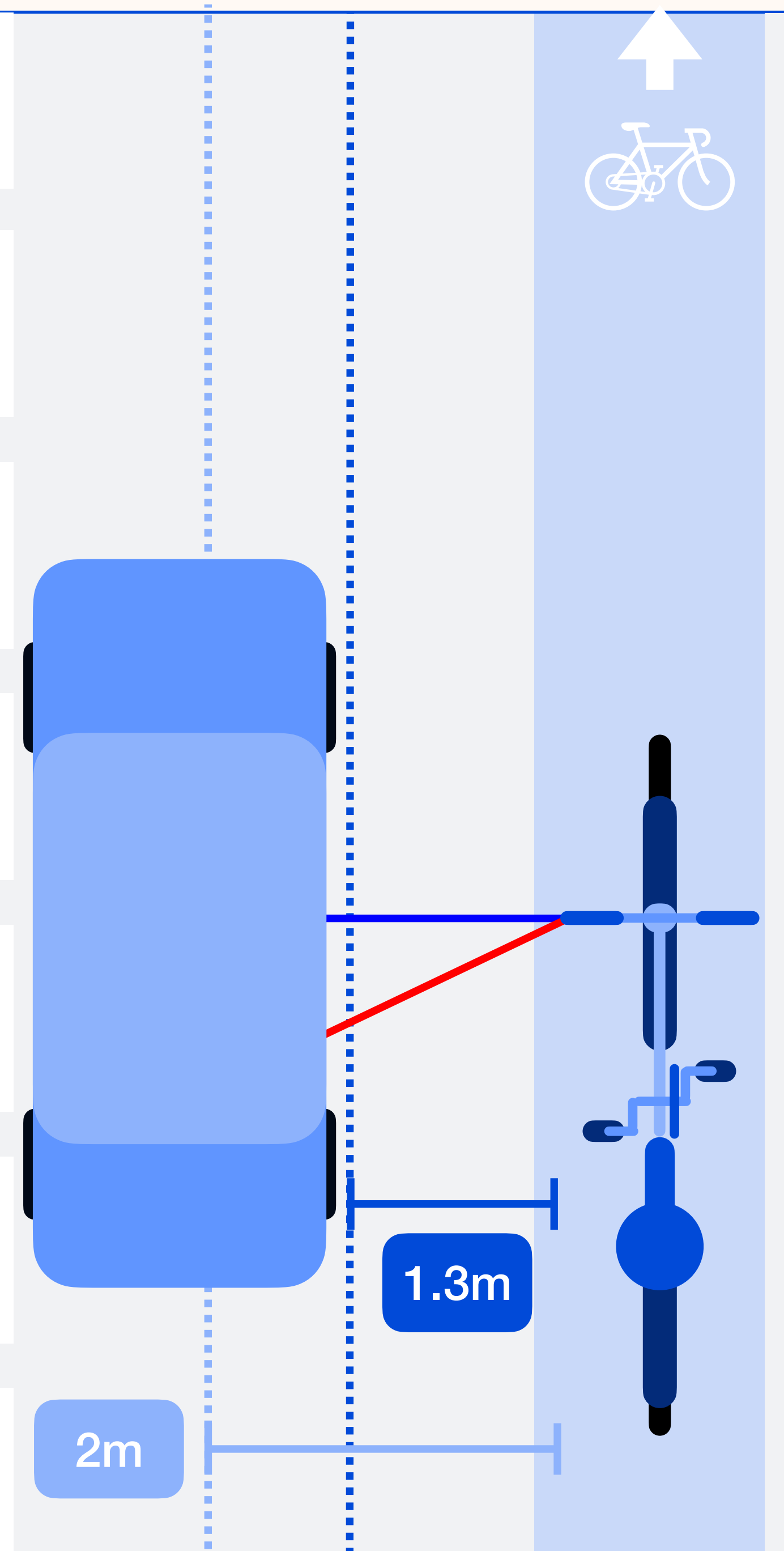
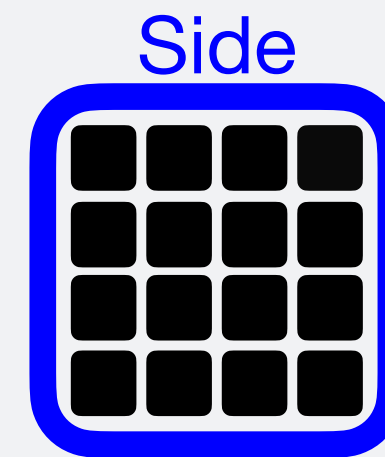
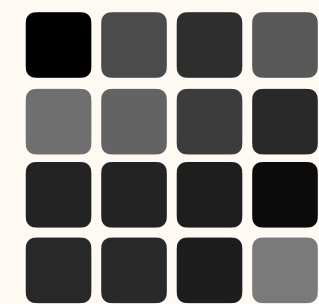

How it Works

Example of car passing bike

Car Pass Detected

Nothing Detected

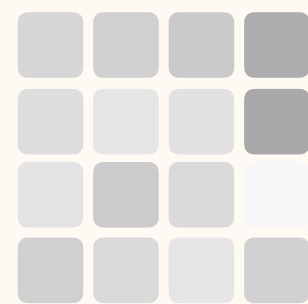

Partial

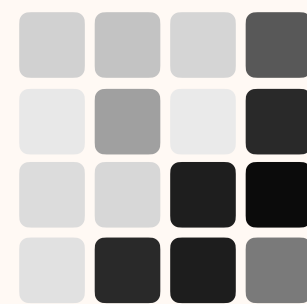

Close Proximity

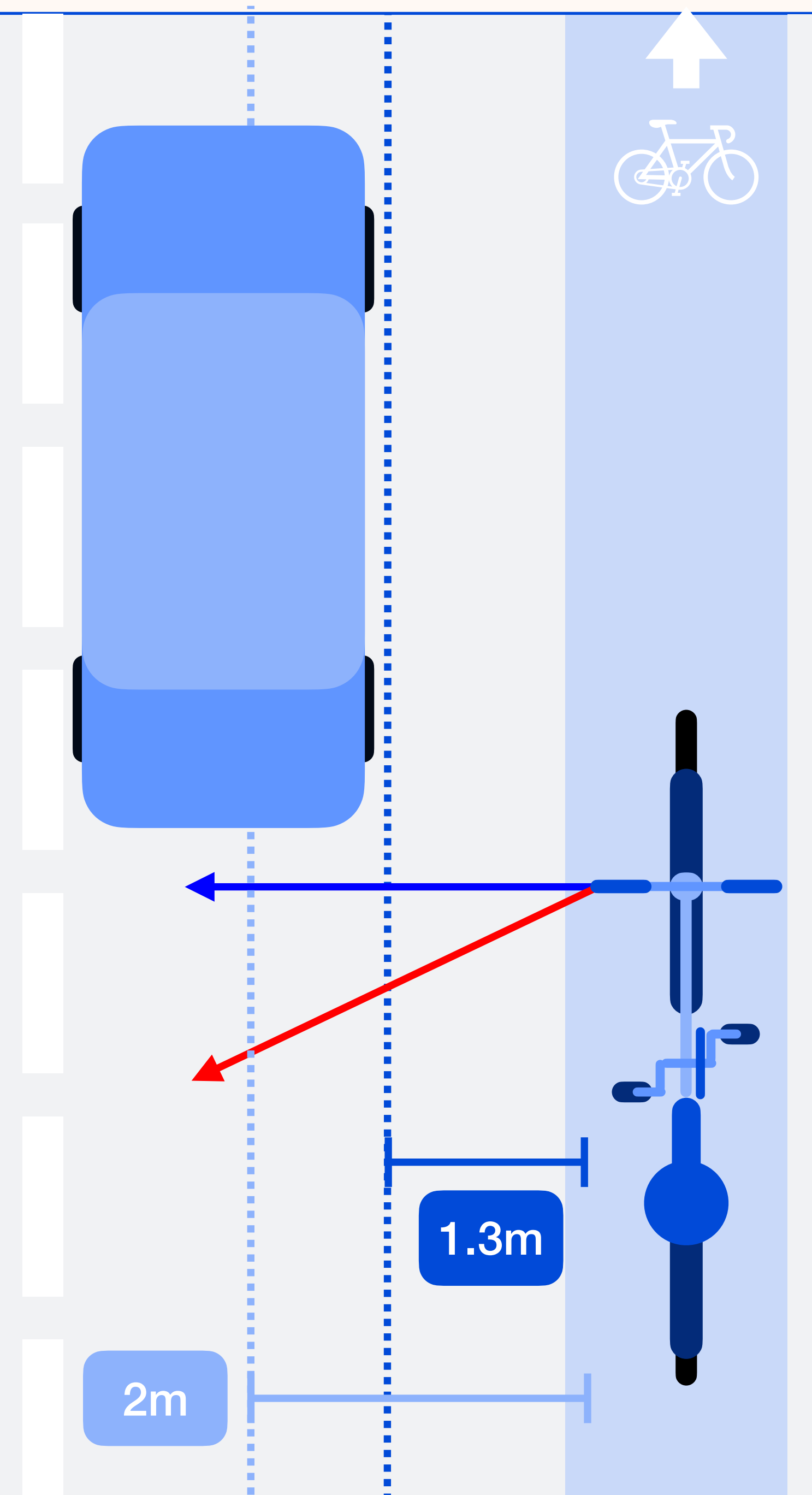
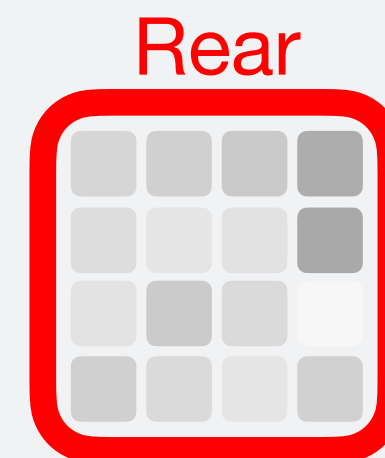
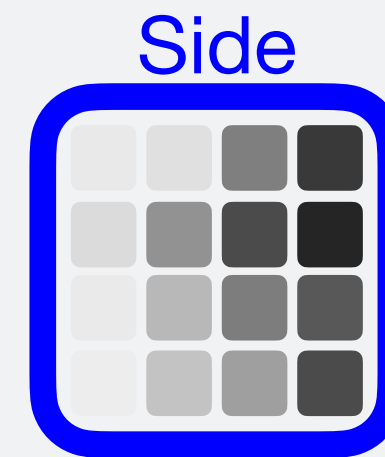
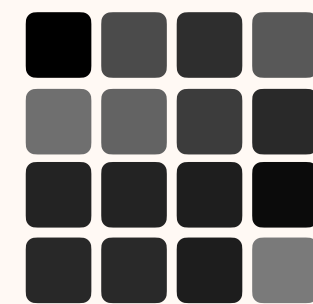

Sensor Validation

Validating Measured Proximity



Sensor Validation

Validating Measured Proximity

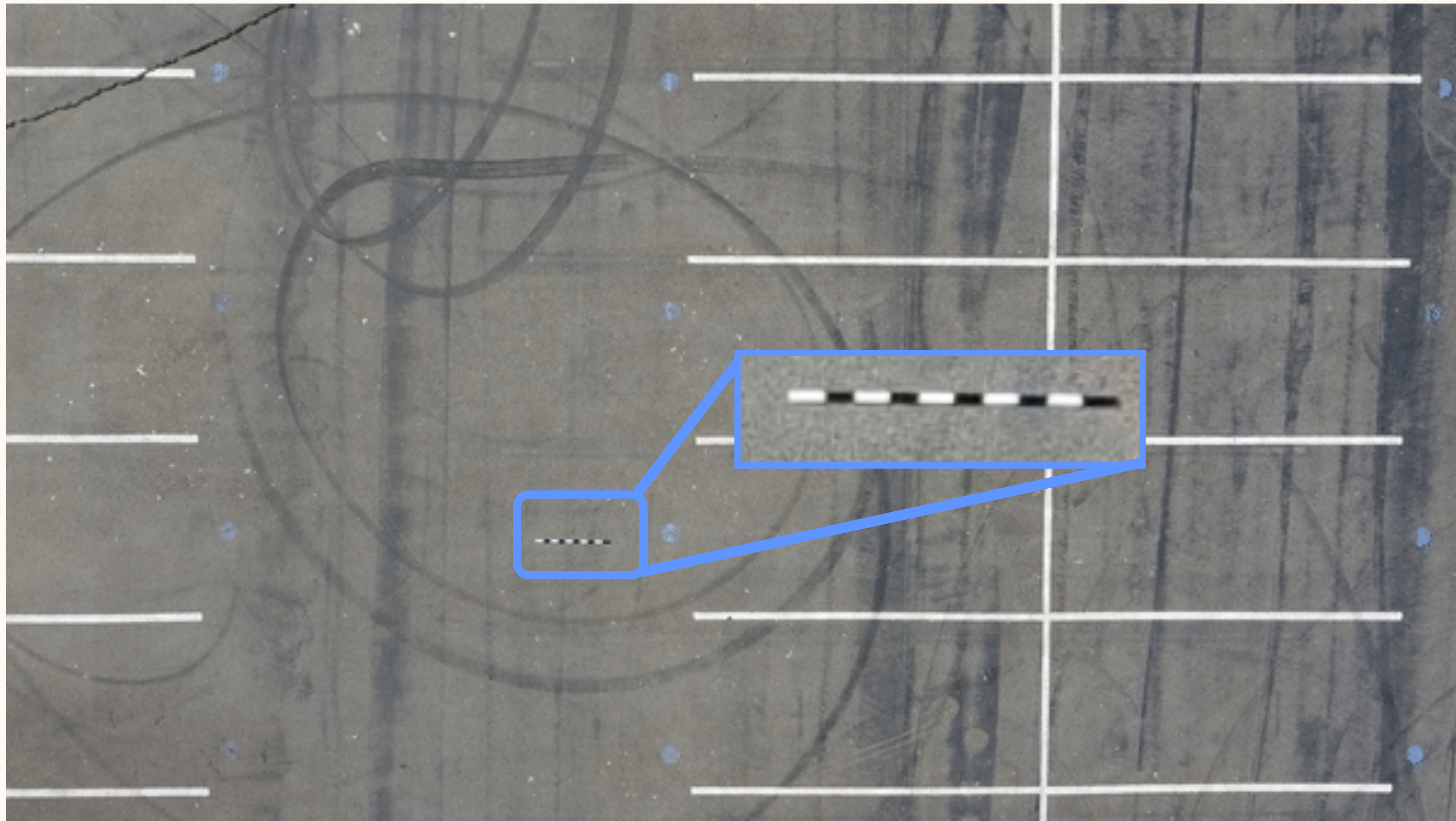

Sensor Validation

Validating Measured Proximity

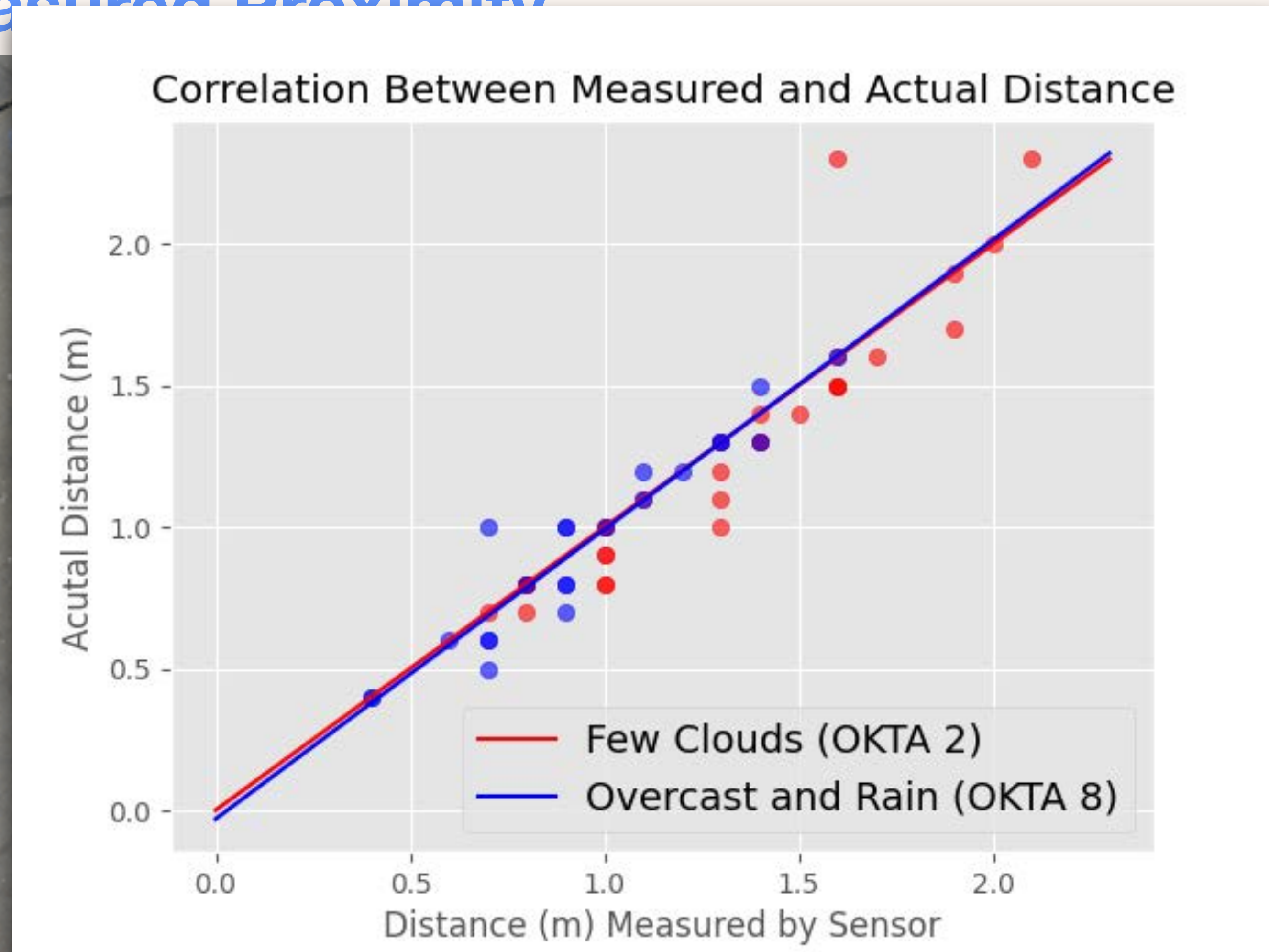

Car Pass Detection Validation

Validating sensor triggers are automobiles

Sensor Recordings + Egocentric Recordings

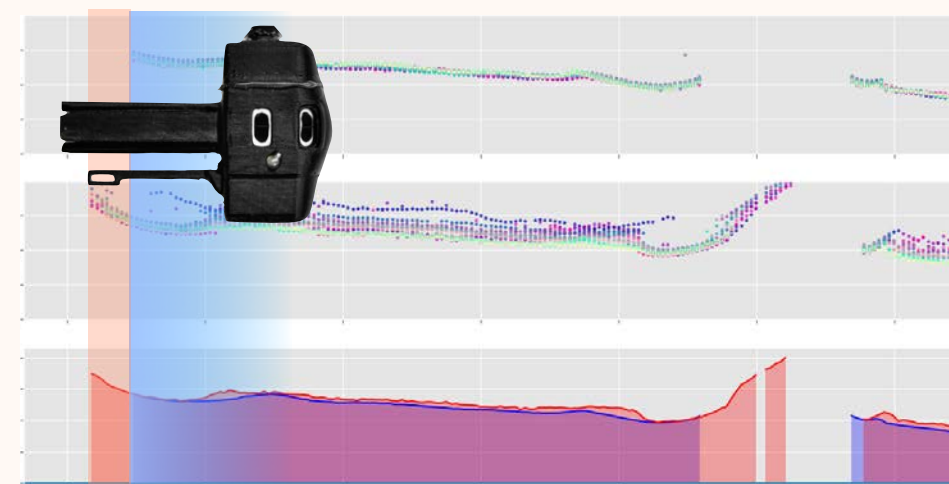
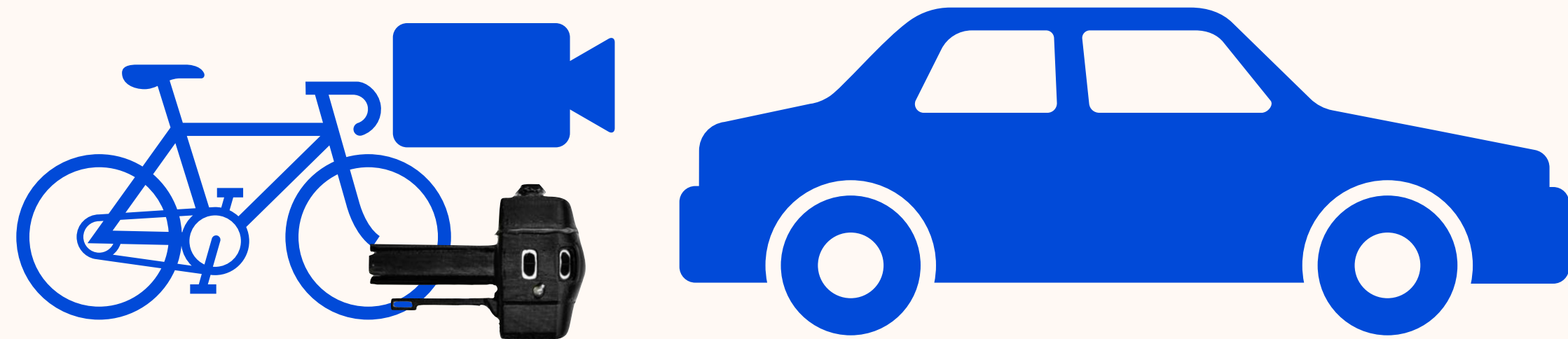

Manually Labeled Sensor Triggers as Cars

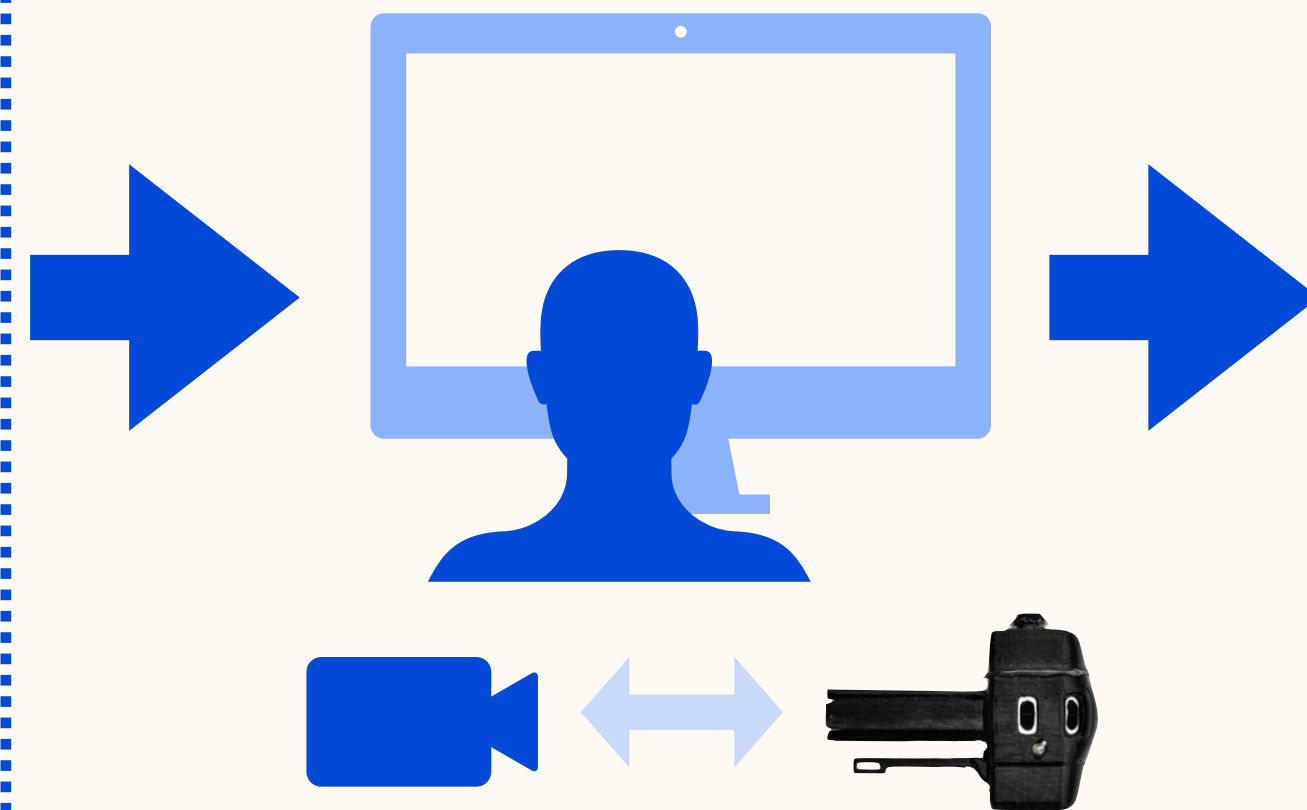

Evaluation

0.915 F1 Score

	T	F
T	96.4%	3.6%
F	1.7%	98.3%
	T	F
	Predicted	

Longitudinal Deployment

Mapping Close-passes at scale

- Now that we trust sensor measurement and triggers.
- Deployed with **15x cyclists** over **2 months** covering 1,000 miles (1609.34 km) traveled.
- **Aggregated a crowdsourced map** of close passes across all riders totally passively.
- Evaluate it against existing measures of safety.

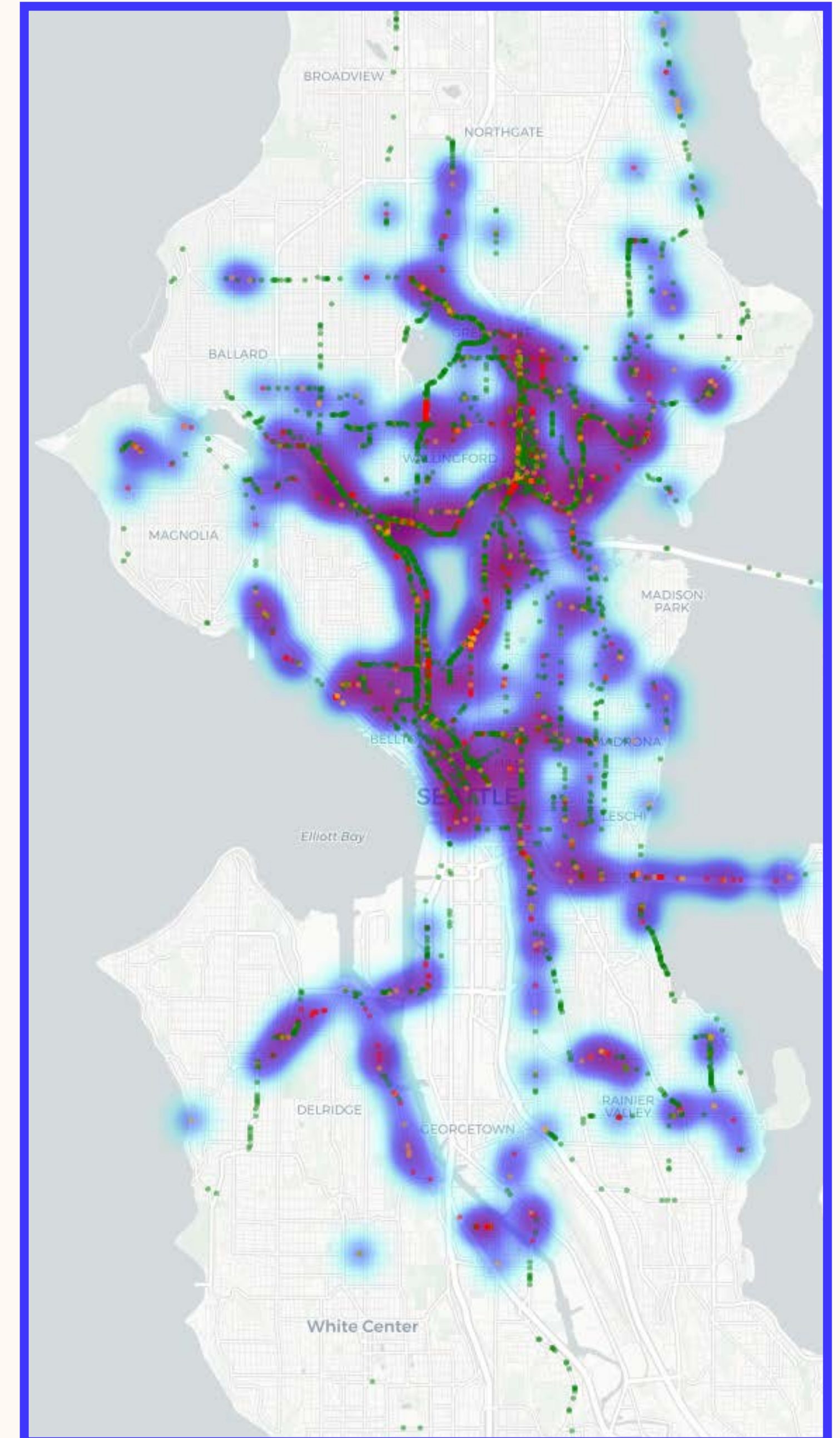

Close Pass Map

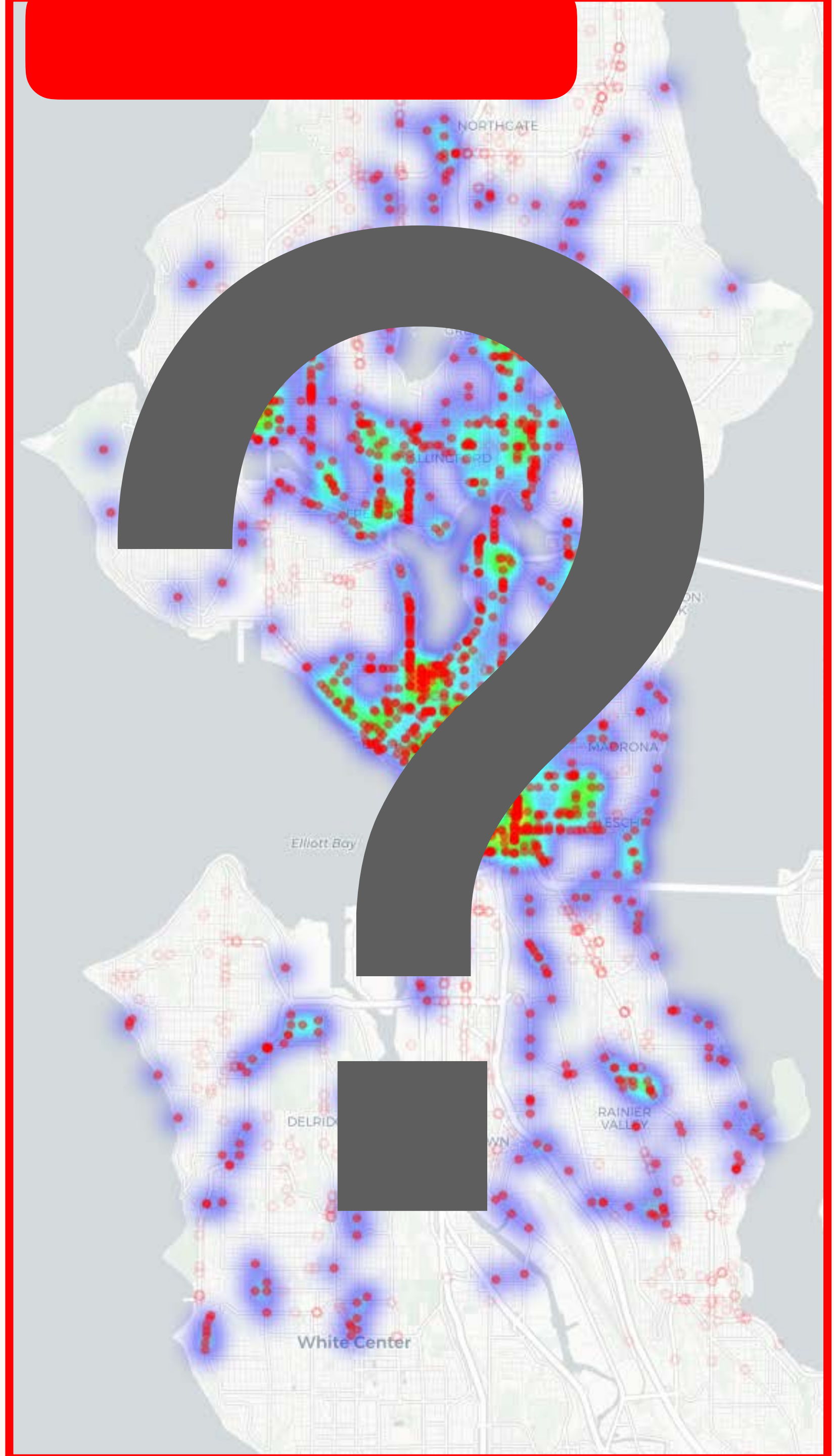
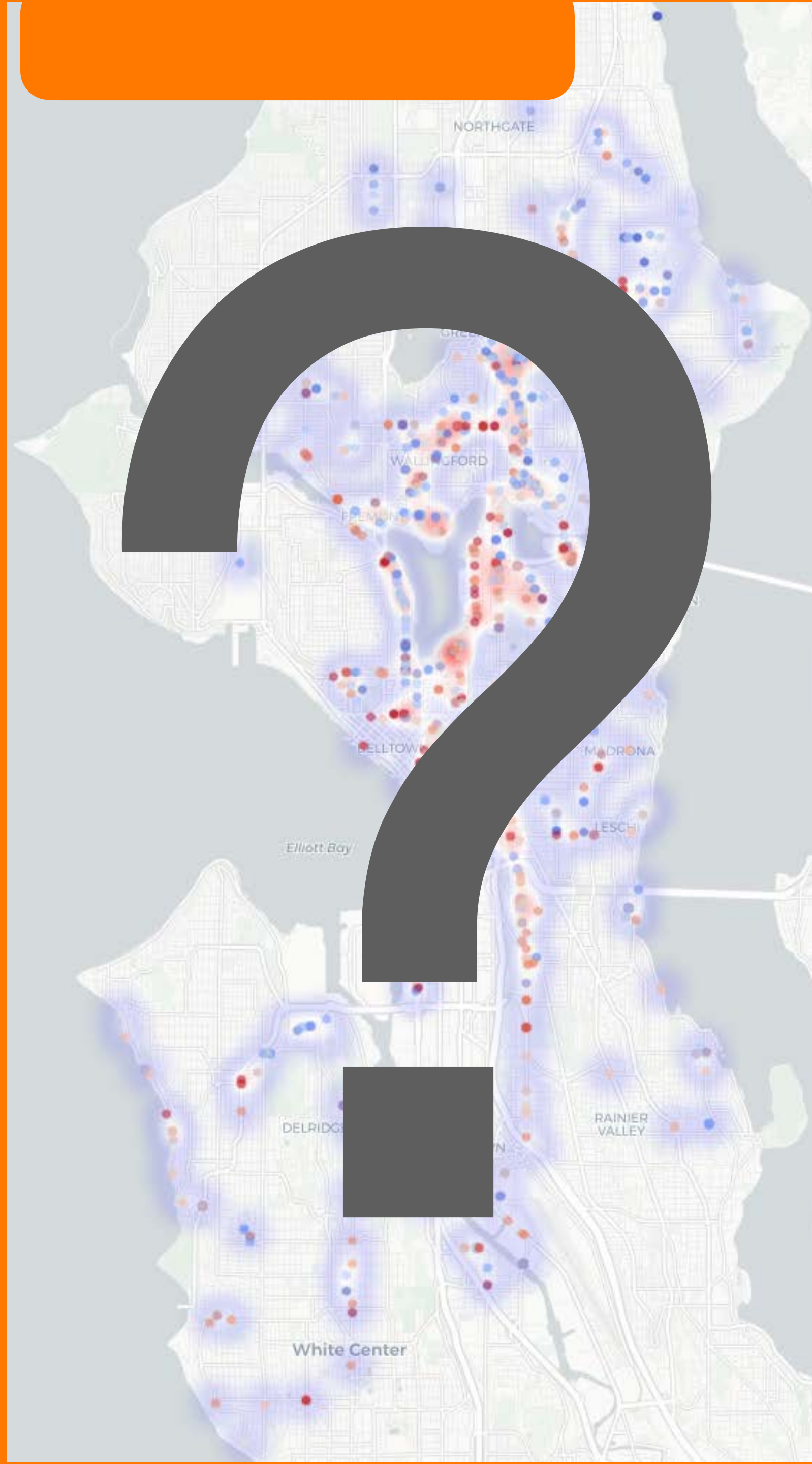
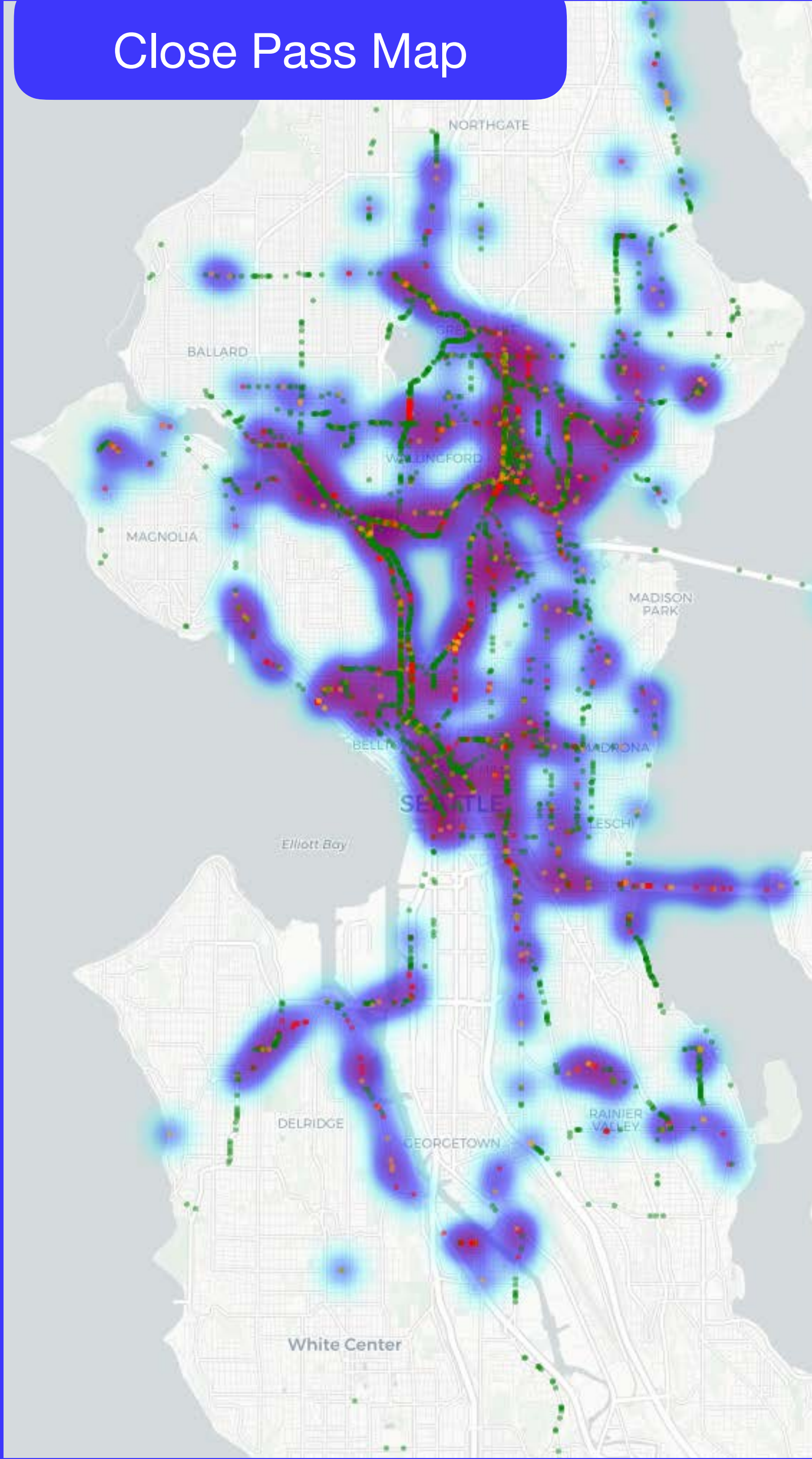

Existing Measures of Safety

Historic collisions

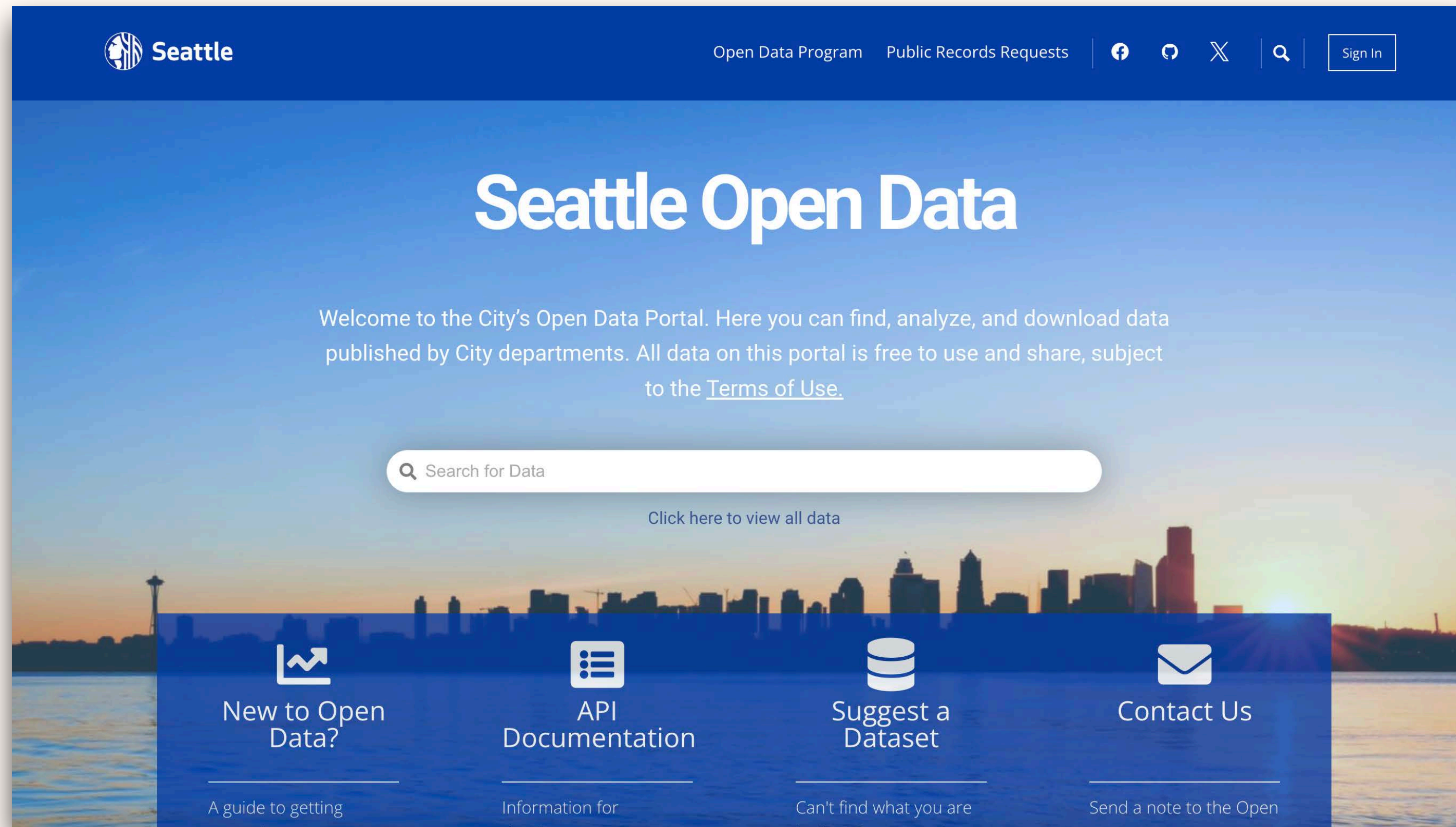

5 years of historically reported collision between drivers and cyclists.

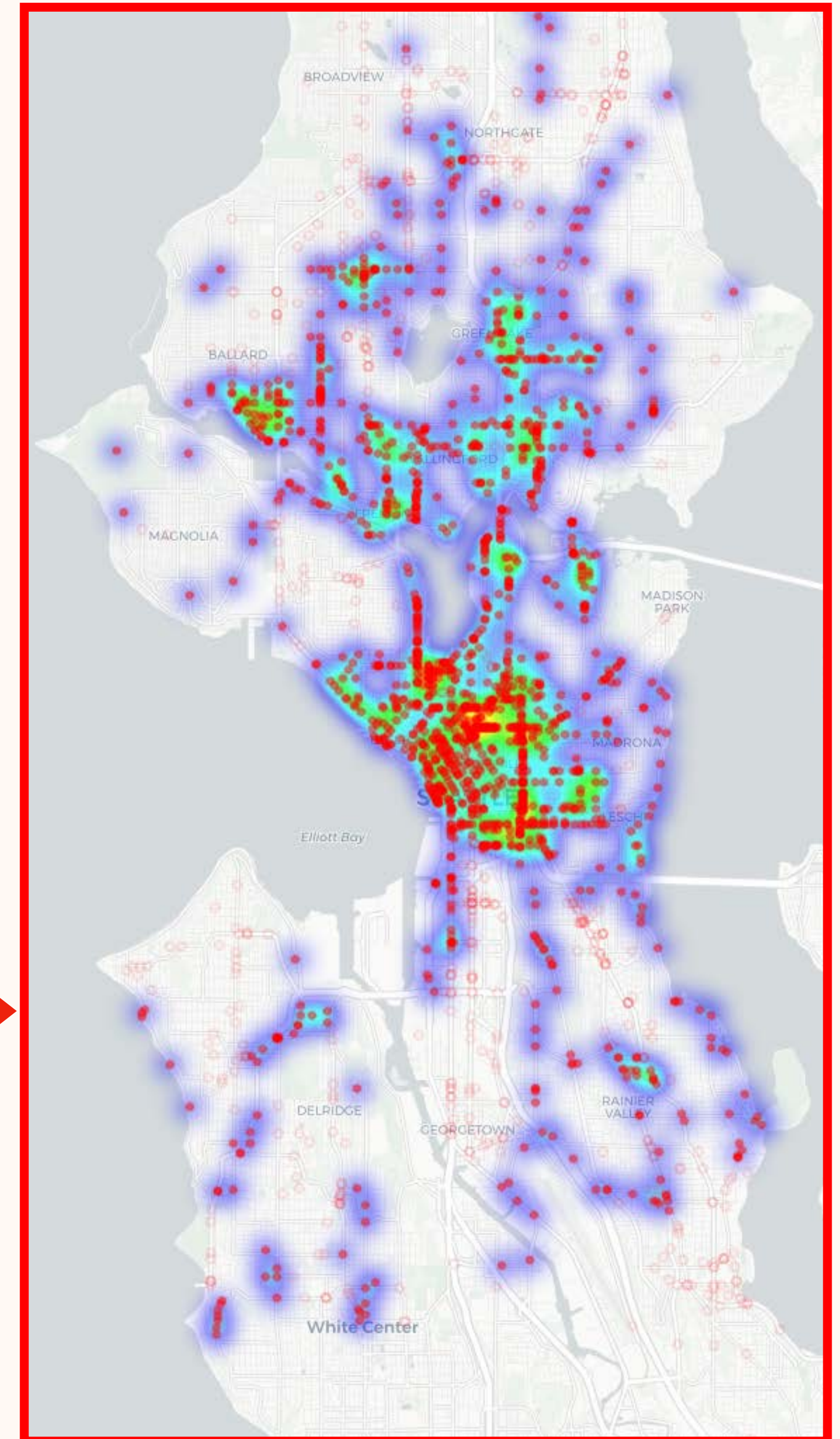

Existing Measures of Safety

Perceived safety

Location 7: Please review and provide your perceived safety of biking at this location. Google Street View URL:

<https://www.google.com/maps/@47.6952587063027,-122.28694402583416&heading=0>

1 being Very Safe, 4 being Neither Safe nor Unsafe, and 7 being Very Unsafe

1 2 3 4 5 6 7

Very Safe Very Unsafe

Have you biked on this road before? If unsure, select No.

Yes

No

(Optional) Why did you assign this the rating you did?

This question is optional. Please explain your reasoning if you'd like.

Long answer text



N=76 for 30 minutes each equating to ~40 hours of active labor.

Close Pass Map

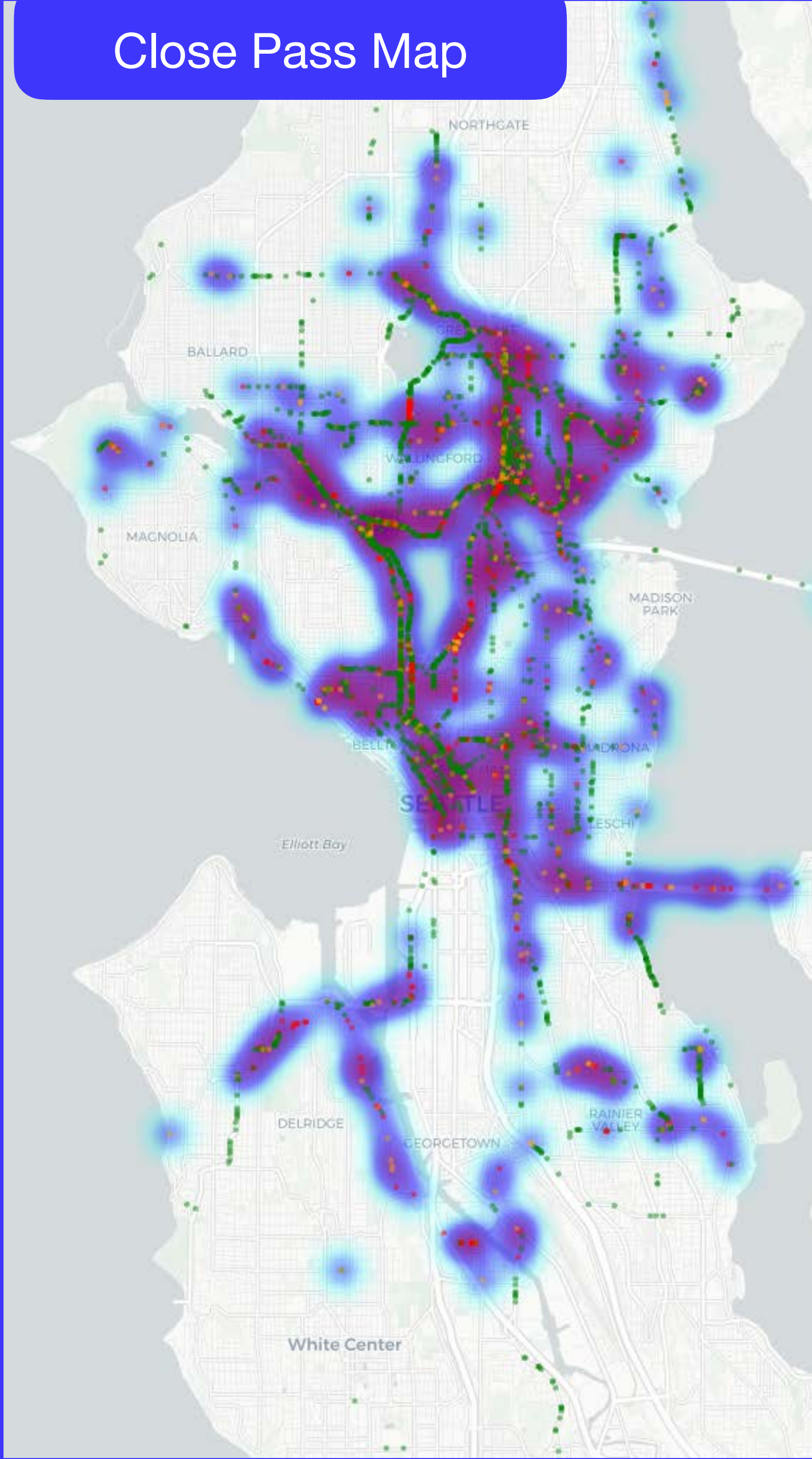

Perceived Safety Map

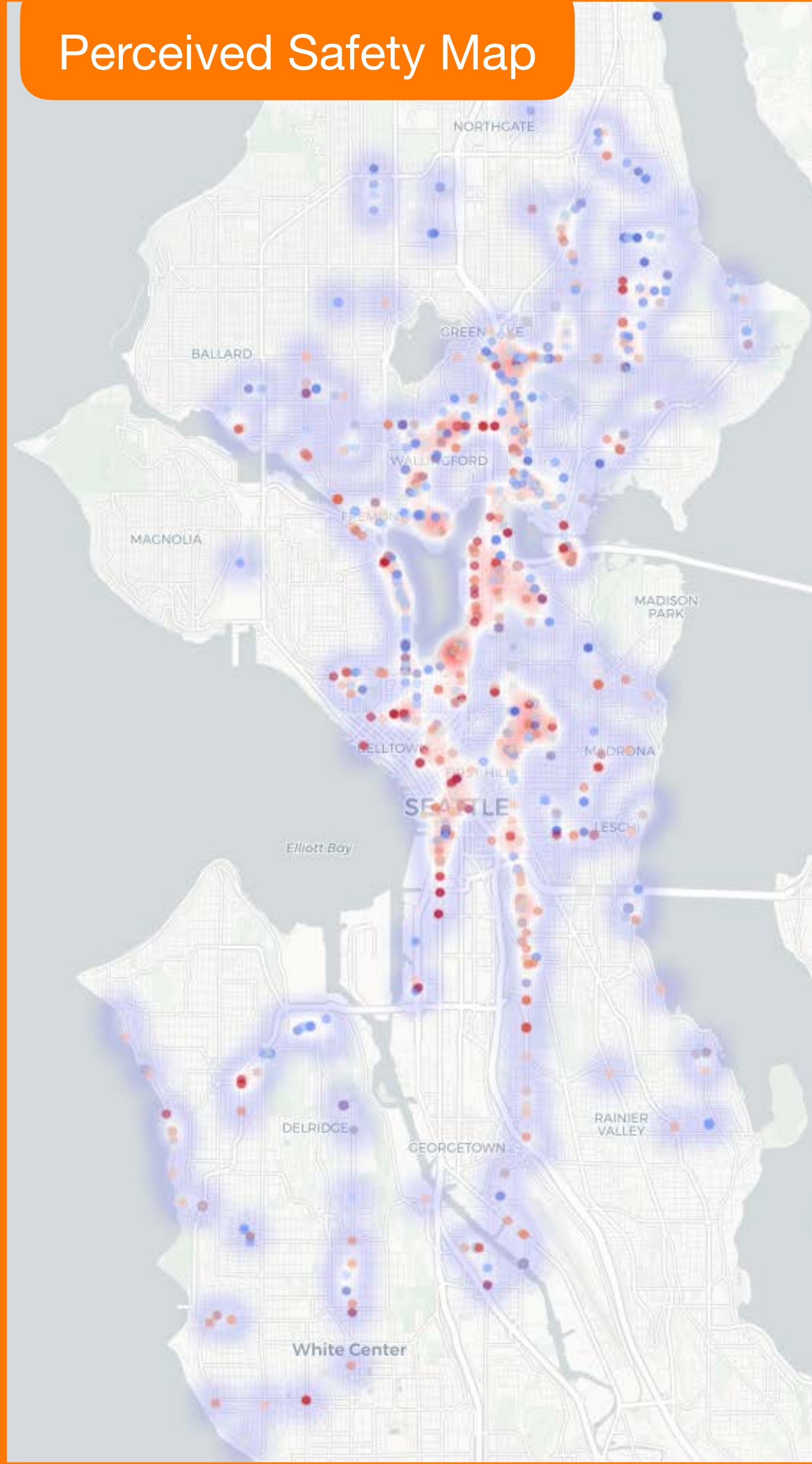

Collision map

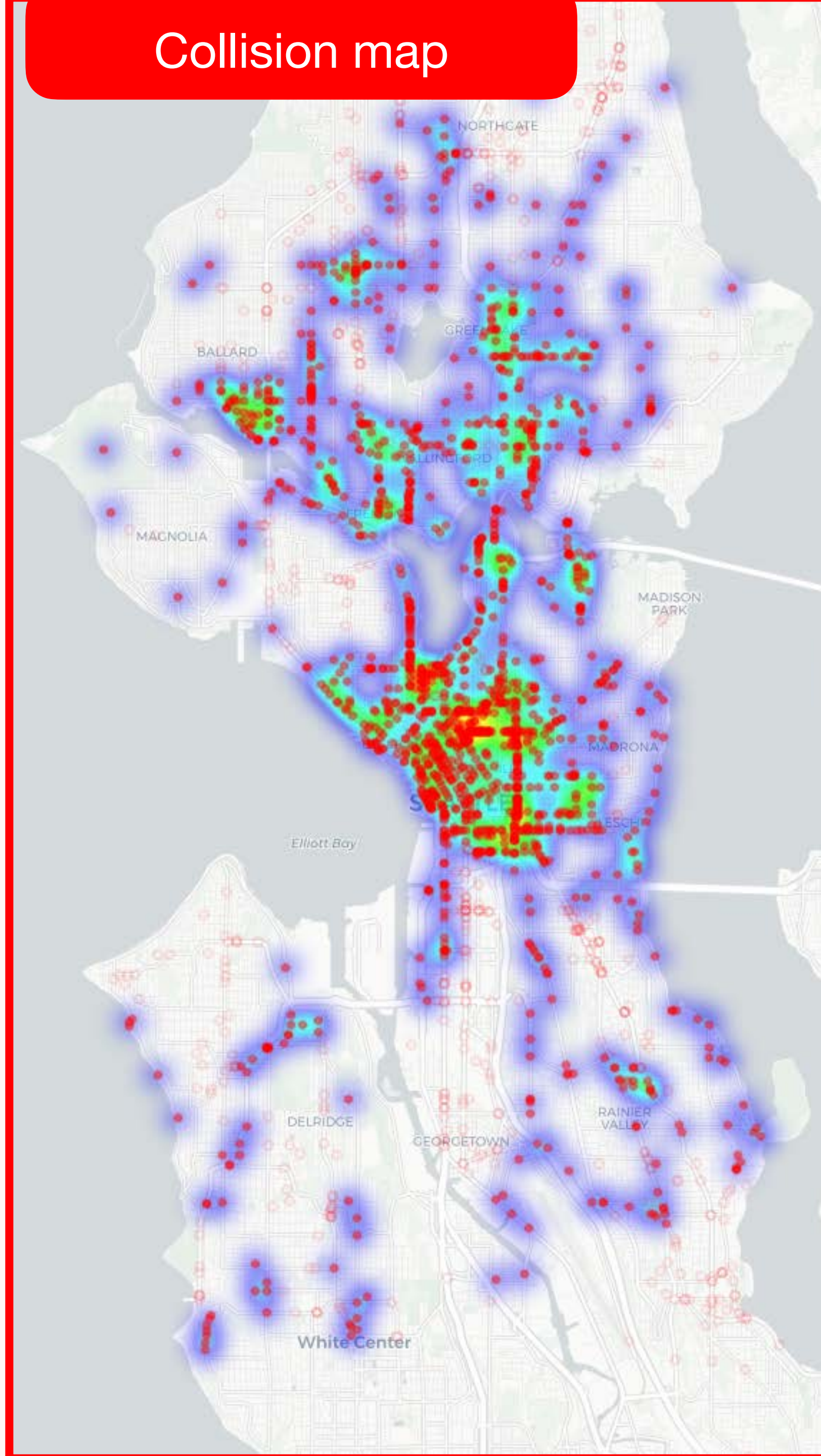

Close Pass Map

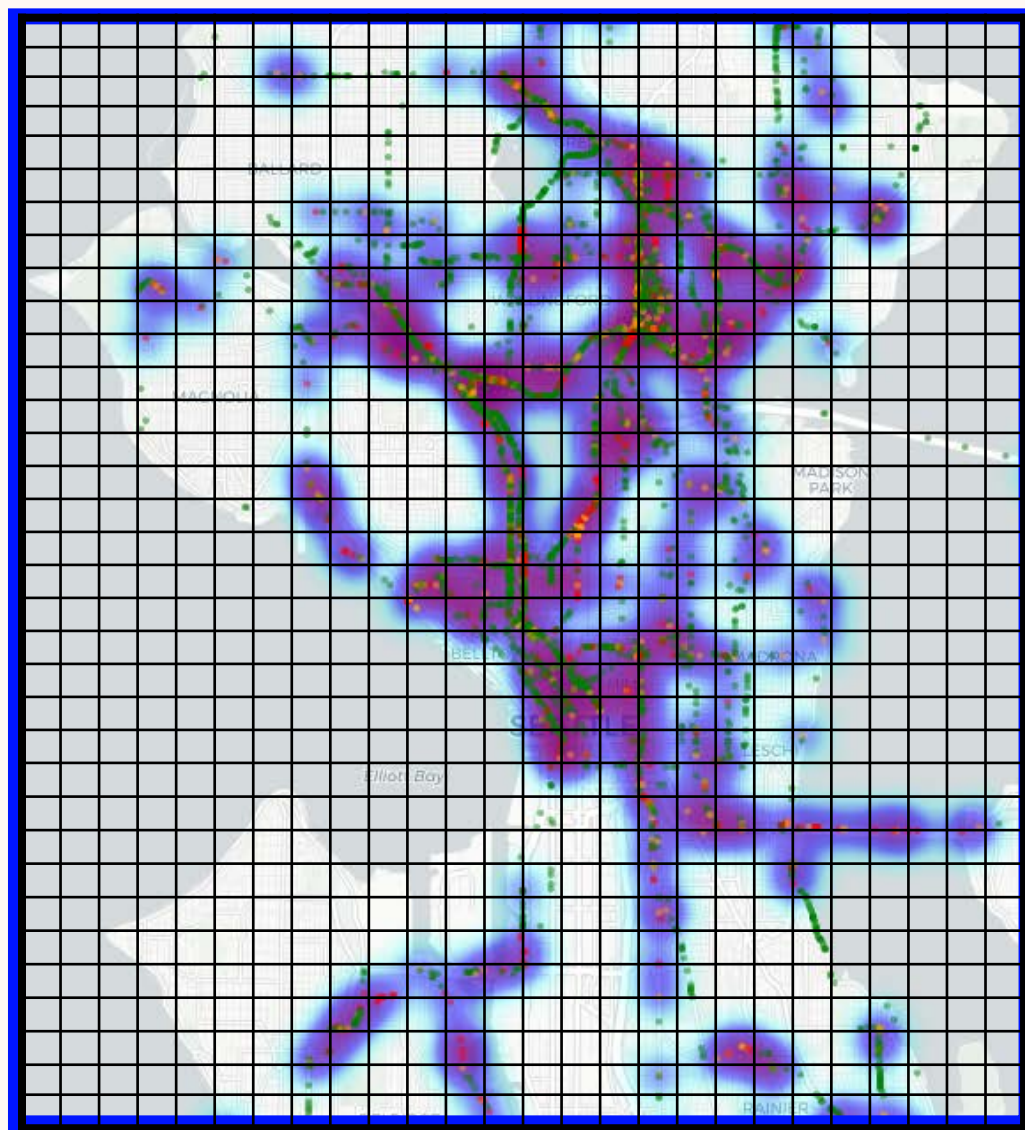
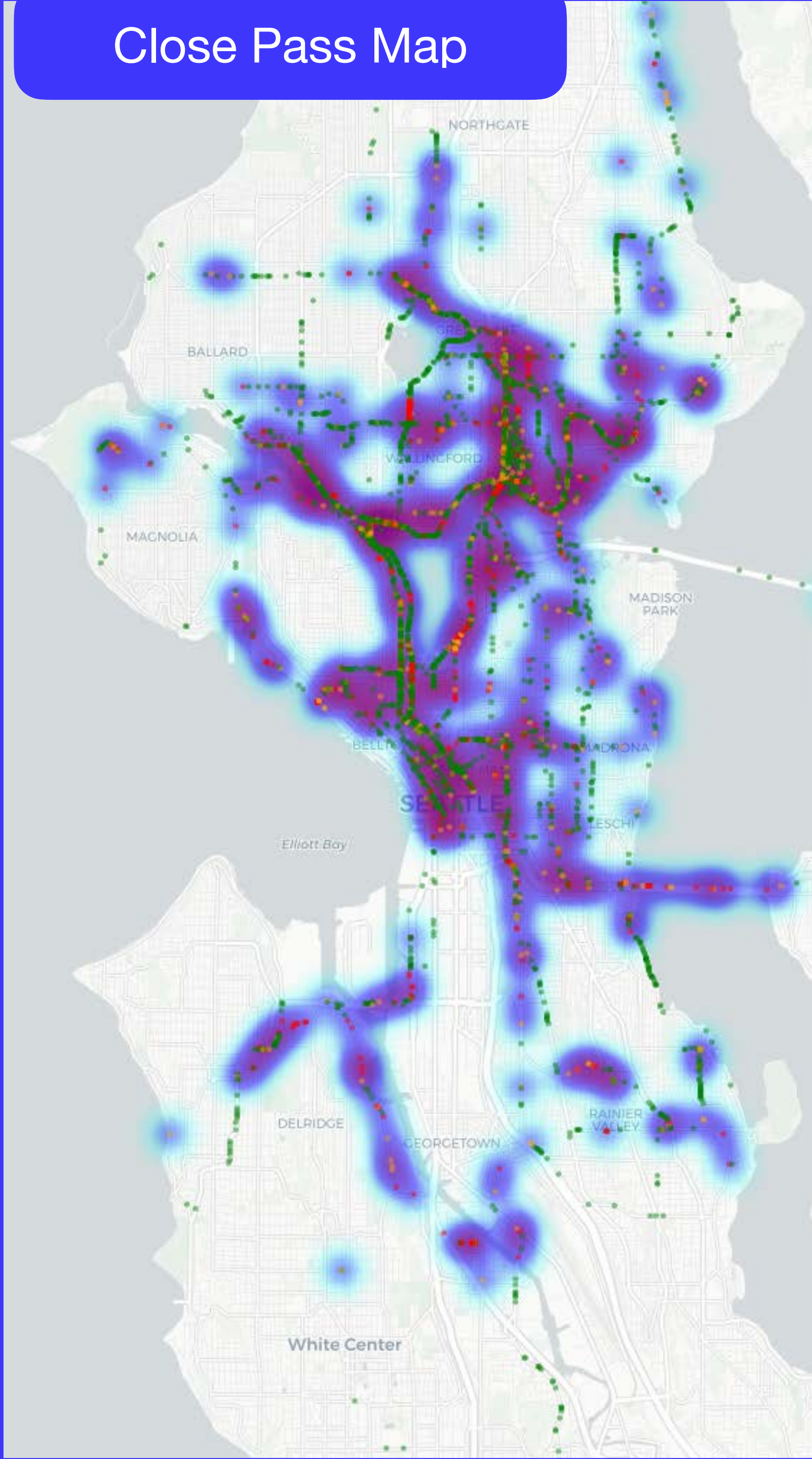

Collision map

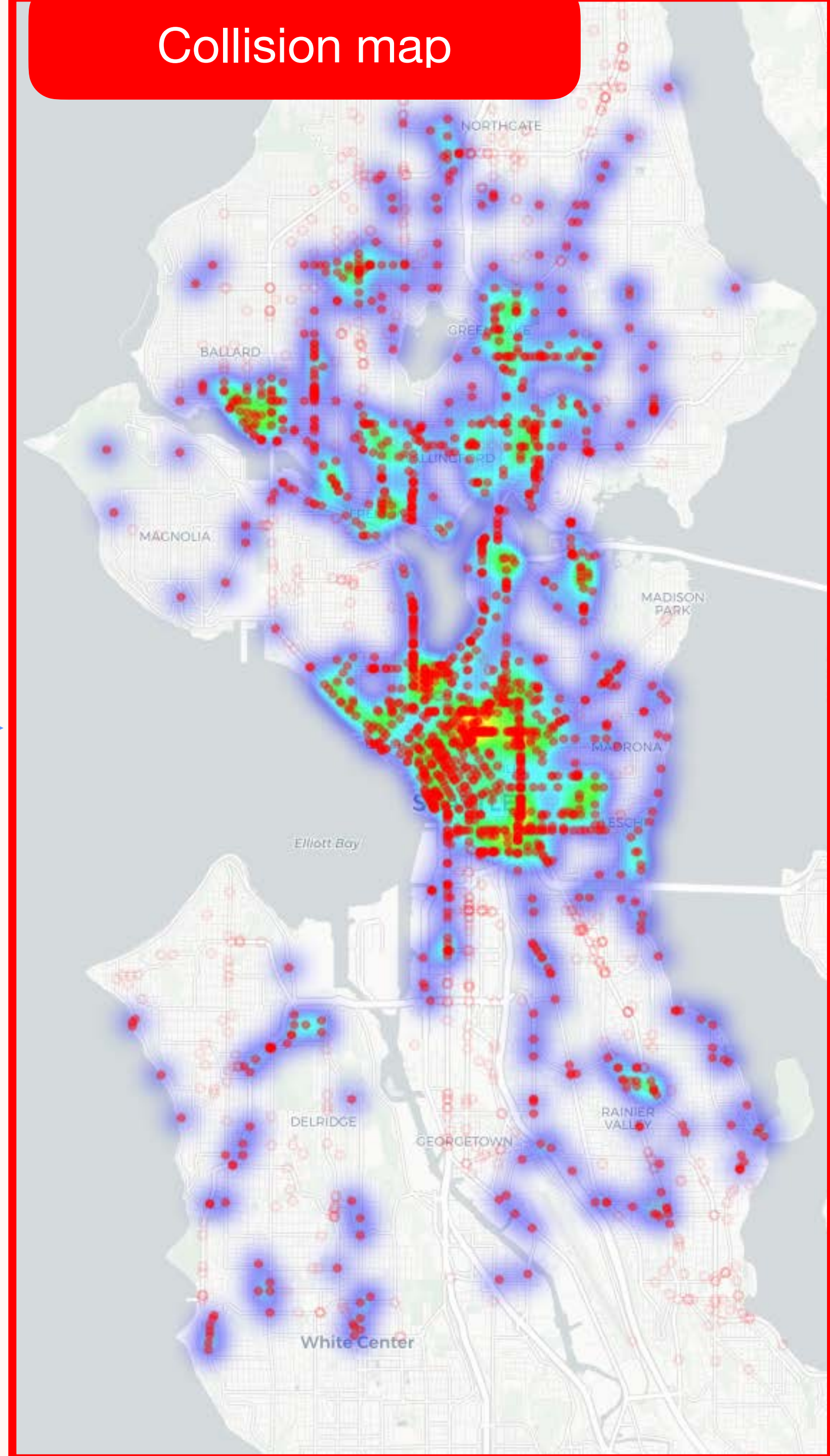

Calculate comparisons between metrics across subregions of the city.

I encourage you to read the paper, but in summary:

Close Pass Map

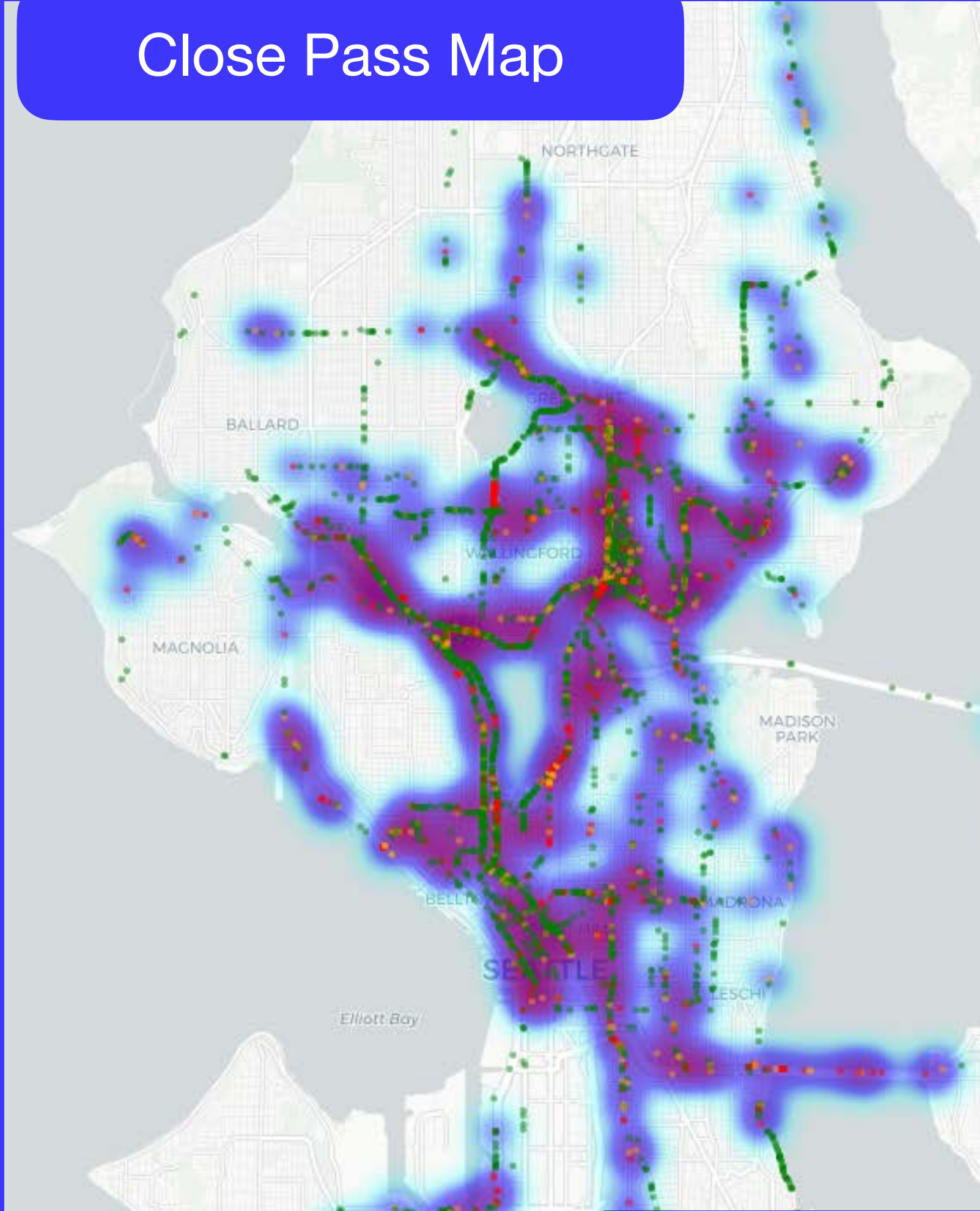

The presence of close passes at a location indicate a higher empirical risk at that location as confirmed by historic car-to-cyclist collisions.

Collision map

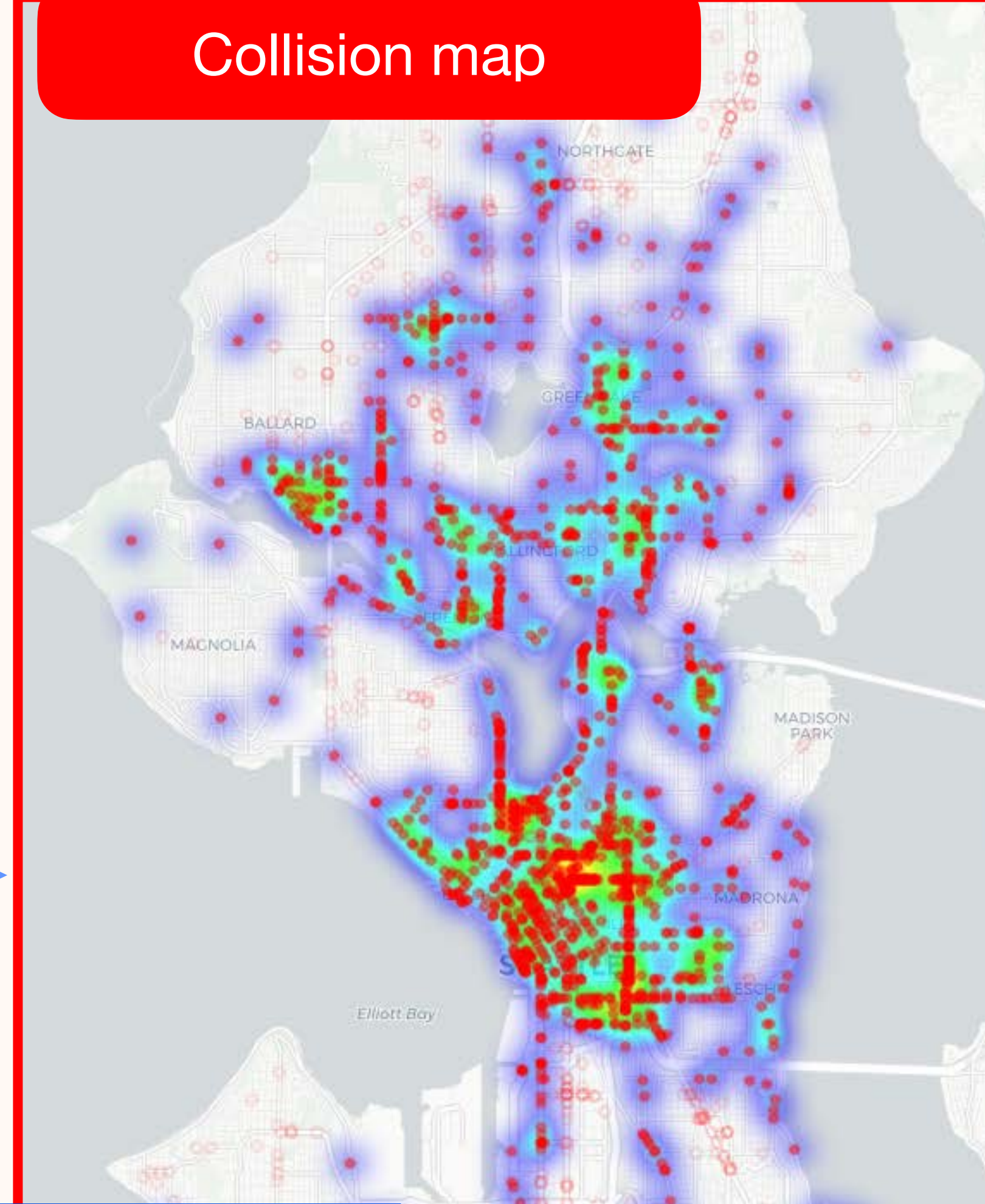

Distance Resolution	Estimating Collisions				Estimating Perceived Safety				Perceived Safety Baseline			
	Corr	ROC AUC	PR AUC	F1	Corr	ROC AUC	PR AUC	F1	Corr	ROC AUC	PR AUC	F1
100m	0.40	0.71	0.63	0.69	-	0.52	0.74	0.49	0.12	0.58	0.62	0.57
150m	0.51	0.74	0.74	0.75	-	0.52	0.82	0.46	0.15	0.60	0.76	0.56
200m	0.60	0.79	0.83	0.80	-	0.53	0.85	0.46	-	0.60	0.82	0.53
250m	0.71	0.85	0.87	0.84	-	0.52	0.88	0.44	0.16	0.61	0.88	0.51

Close Pass Map

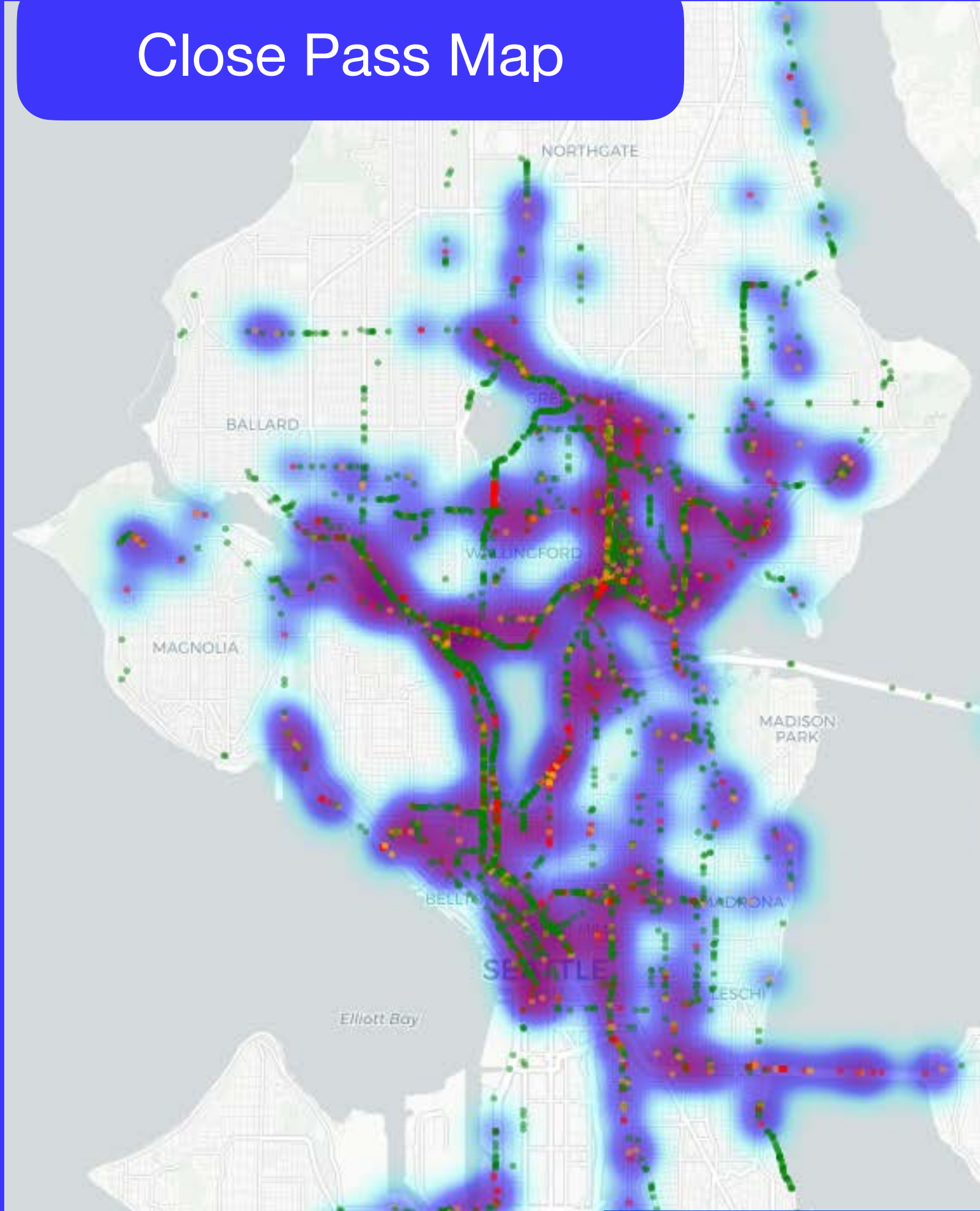

Close passes somewhat indicate perceived safety, but much weaker than they indicate historic collisions.

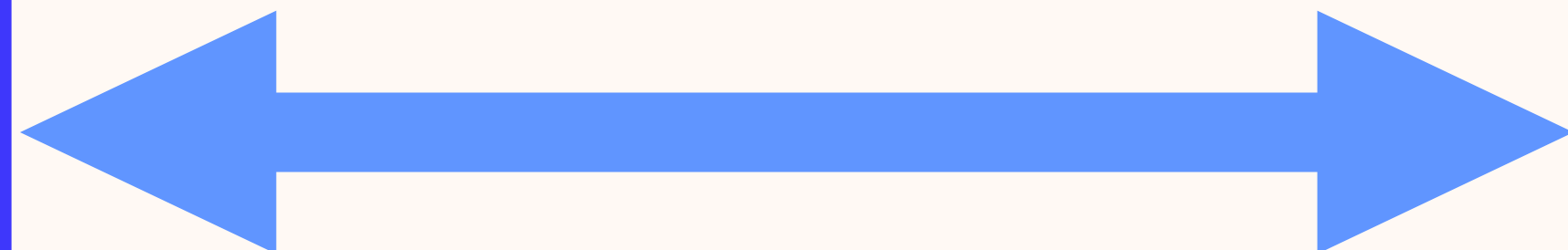

Perceived Safety Map

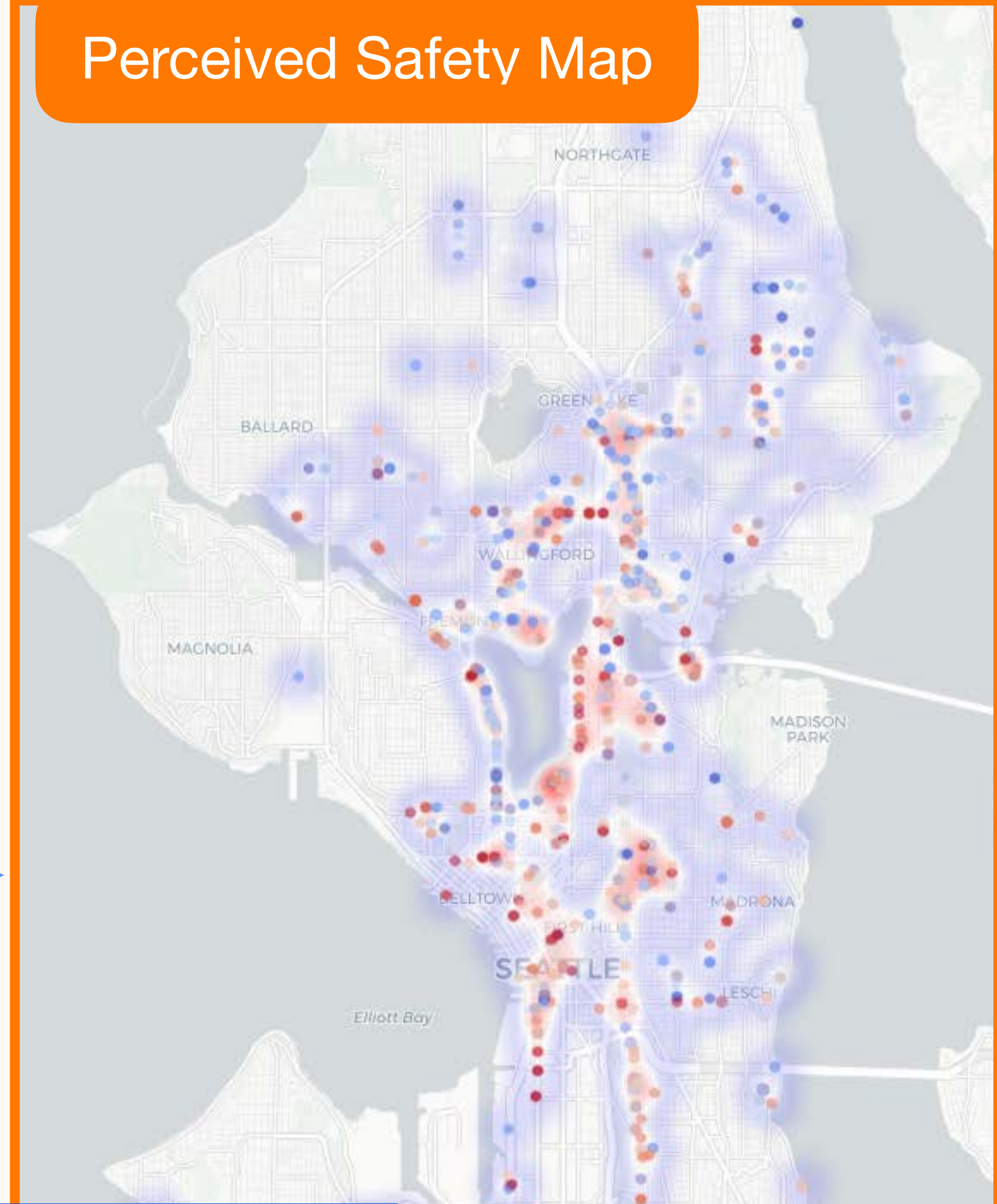

Distance Resolution	Estimating Collisions				Estimating Perceived Safety				Perceived Safety Baseline			
	Corr	ROC AUC	PR AUC	F1	Corr	ROC AUC	PR AUC	F1	Corr	ROC AUC	PR AUC	F1
100m	0.40	0.71	0.63	0.69	-	0.52	0.74	0.49	0.12	0.58	0.62	0.57
150m	0.51	0.74	0.74	0.75	-	0.52	0.82	0.46	0.15	0.60	0.76	0.56
200m	0.60	0.79	0.83	0.80	-	0.53	0.85	0.46	-	0.60	0.82	0.53
250m	0.71	0.85	0.87	0.84	-	0.52	0.88	0.44	0.16	0.61	0.88	0.51

Perceived Safety Map

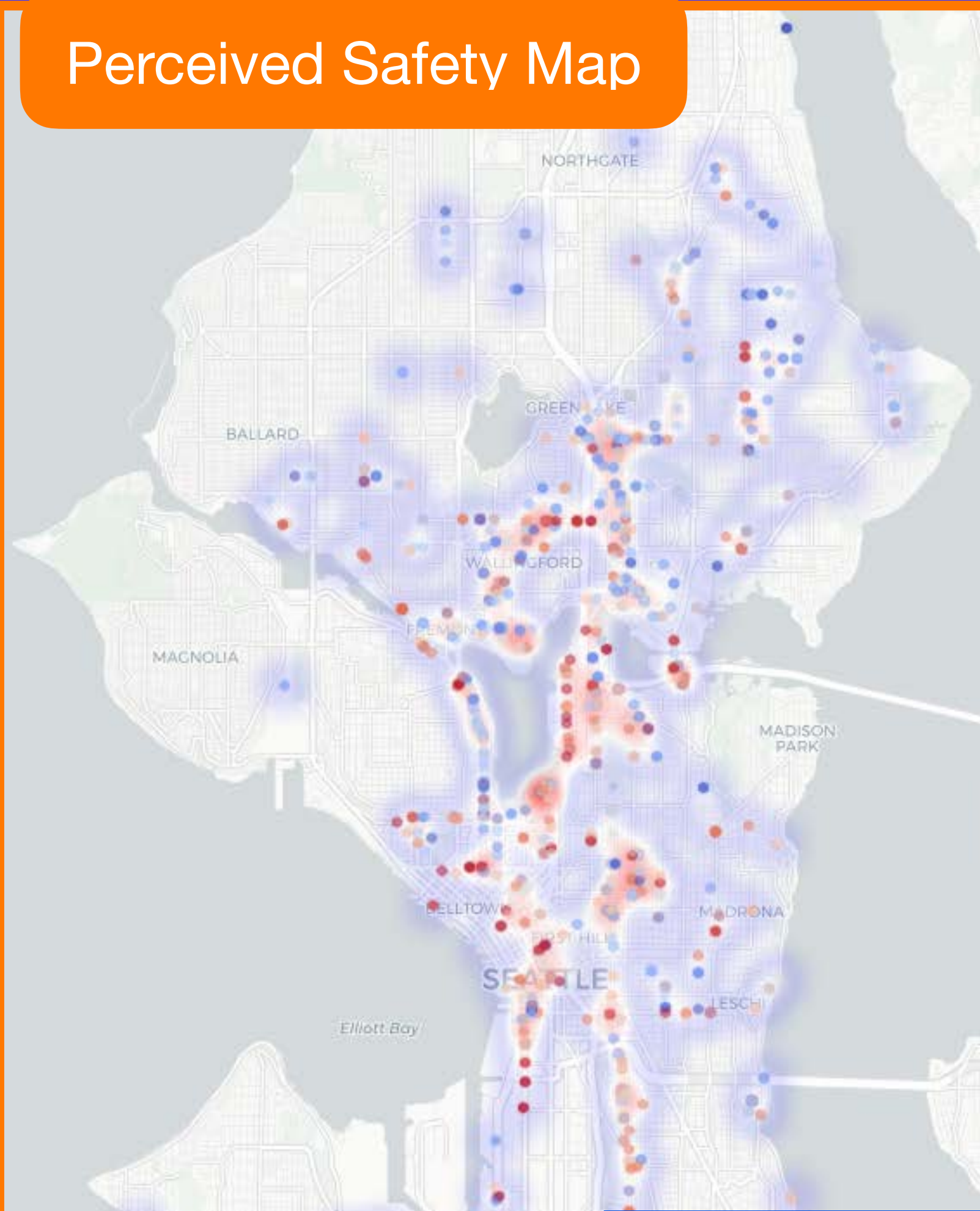

As a baseline: perceived safety is a weaker indicator of empirical collision risk than close passes.

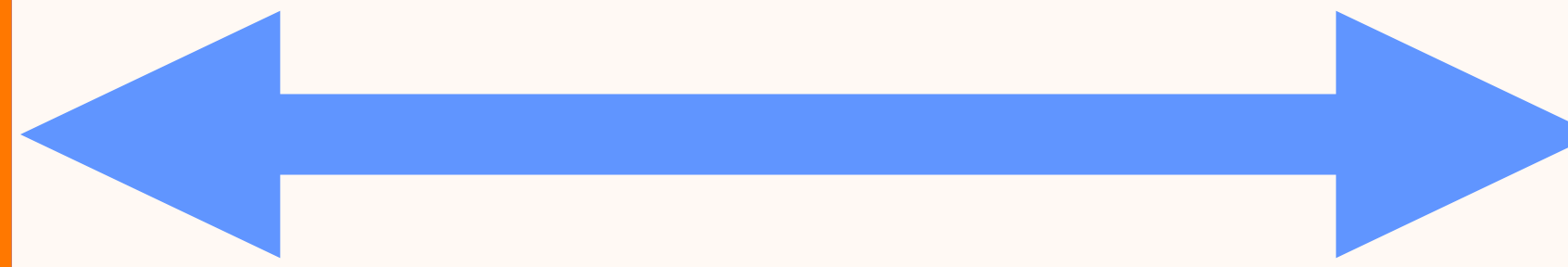

Collision map

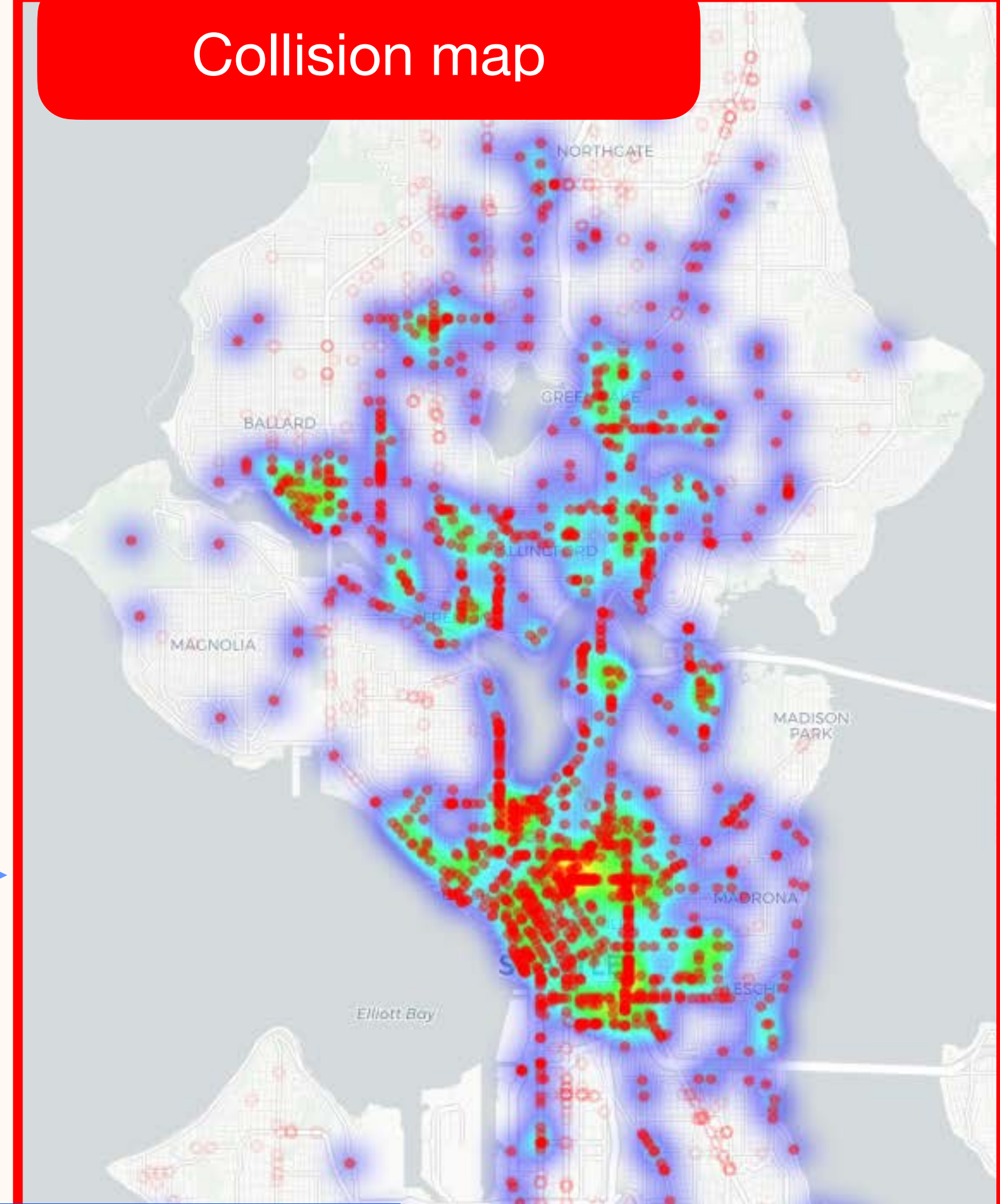

Distance Resolution	Estimating Collisions				Estimating Perceived Safety				Perceived Safety Baseline			
	Corr	ROC AUC	PR AUC	F1	Corr	ROC AUC	PR AUC	F1	Corr	ROC AUC	PR AUC	F1
100m	0.40	0.71	0.63	0.69	-	0.52	0.74	0.49	0.12	0.58	0.62	0.57
150m	0.51	0.74	0.74	0.75	-	0.52	0.82	0.46	0.15	0.60	0.76	0.56
200m	0.60	0.79	0.83	0.80	-	0.53	0.85	0.46	-	0.60	0.82	0.53
250m	0.71	0.85	0.87	0.84	-	0.52	0.88	0.44	0.16	0.61	0.88	0.51

Conclusion

Close Passes for Estimating Safety

- close passes **estimate collisions better** than perceive safety.
- Close passes can be sourced in a **matter of months, without anyone getting hurt.**
- Close passes are sourced entirely **passively** with no user input.
- Close passes captures changes in safety **longitudinally** over time.

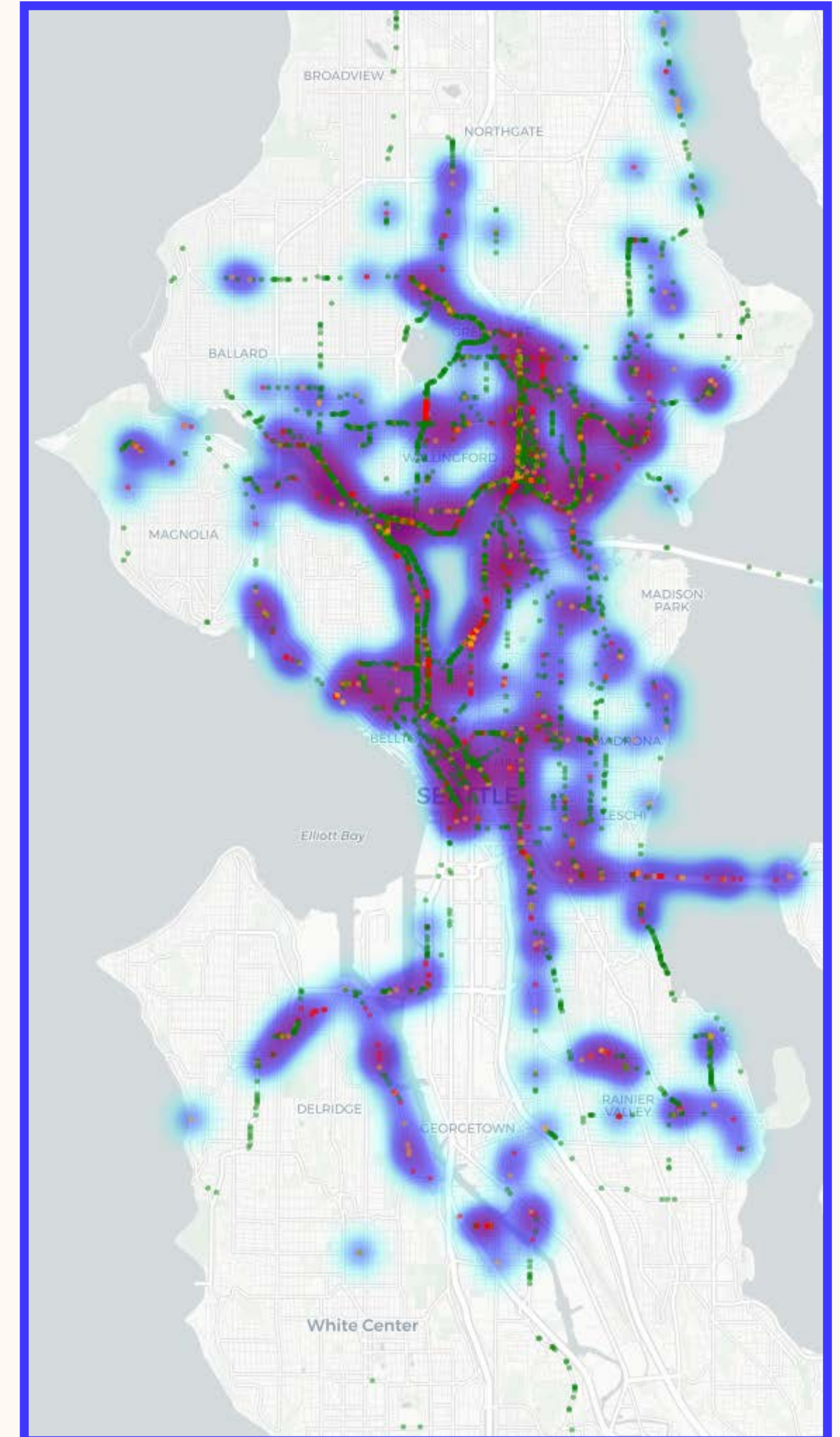

Thank You!

Questions?

Please feel free to reach out with any questions



Joe Breda

University of Washington



Keyu Chen

Gridware



Thomas Plötz

Georgia Tech



Shwetak Patel

University of Washington



<https://joebreda.github.io/>

I will be on the job market soon!